



INSTALLATION MANUAL
Ultra Galactica

AVE-WPST-54G-IM

TABLE OF CONTENTS

PART 0	DOCUMENT ADMINISTRATION	3
0.1	DOCUMENT APPROVAL.....	3
0.2	AMENDMENT RECORD PROCEDURE	4
0.3	AFFECTED PAGES PROCEDURE	5
PART 1	INSTALLATION DATA	6
1.1	ULTRA GALACTICA™	6
1.2	OPERATING INSTRUCTIONS.....	7
1.3	INSTALLATION SCHEMATIC / WIRING DIAGRAM	7
1.4	CONTROL & POWER INPUTS	7
1.5	TECHNICAL SPECIFICATION.....	8
1.6	TECHNICAL DRAWING	10
1.7	WIRING CHART	11
1.8	OPTIC PERFORMANCE	12
1.9	EQUIPMENT LIMITATION	40
1.10	TESTING THE LIGHTS BEFORE INSTALLATION.....	40
1.11	NOTES ON INSTALLATION	41
1.12	CARE AND CLEANING OF LIGHTS.....	42
1.13	CONTINUED AIRWORTHINESS INFORMATION	42
1.14	ETSO REQUIREMENT DEVIATION.....	44
1.15	ROHS COMPLIANCE STATEMENT.....	44
1.16	EU REACH REGULATION (EC) No. 1907/2006	44

Part 0 Document Administration

0.1 Document Approval

This document has been established in accordance with an alternative procedure to DOA approved under EASA AP429.

This installation manual is applicable for following part numbers (Modification status Mod(4) or higher):

- Ultra Galactica (Red) **AVE-WPSTR-54G Mod(4)**
- Ultra Galactica (Green) **AVE-WPSTG-54G Mod(4)**

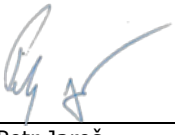
Compiled by:  _____ 16. March 2026
Petr Jaroš
Engineer, Aveo Engineering Group, s.r.o.

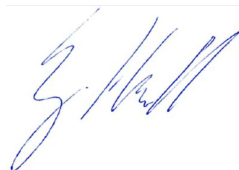
Approved by:  _____ 16. March 2026
Georg Hartl
Head of DO, Aveo Engineering Group, s.r.o.

0.2 Amendment Record Procedure

The master copy of this document shall be kept electronically as a read only document under the control of Aveo Engineering Group, s.r.o. as Master Copy.

ALL amendments to this manual will initiate a raise of issue.

The original issue will be identified by "**01**", and subsequent issues will be numbered sequentially from 02 to 99 in Table 01 - **Issue No.** column.

ALL issues of this document will be approved by Head of DO.

Issue No.	Details	Date of issue	Affected Pages
01	Initial Issue	15 Jun. 2015	ALL
02	Addition of FAA required statements	10 Nov. 2015	7, 9
03	Change in category of section 4	14 Feb. 2017	7
04	Editorial corrections as marked Summary of environmental tests removed (not marked) Technical specification and dimensional definition adopted LED schematics adjusted	28 Apr. 2017	6-15 7 9-10 15
05	Weight update Electronics data update Drawing update (not marked) ROHS addition	05 Jan. 2021	5, 7 7 8 13
06	Weight and other technical specification update DO160 Table Drawing update (not marked) Text addition in section 1.7 Optic simulation addition Text update ETSO Requirement Deviation addition EU Reach addition	16. Mar. 2026	6, 8, 13, 41 9 10 11 12-39 40, 42 44 44
Table 01: Record of Document Amendments			

0.3 Affected Pages Procedure

ALL pages affected by ANY raise of issue of this document will be listed in Table 01 - **Affected Pages** Column.

The reason(s) for **EACH** raise of issue and the description of respective change will be provided in Table 01 - **Details** Column.

Changes from the previous issue are shown as follows:

- a) new text is highlighted with yellow shading: **new**
- b) deleted text is shown with yellow shading and a strike through: ~~deleted~~

Part 1 Installation data

1.1 Ultra Galactica™

The **Ultra** series lights are a very popular choice for certified and general aviation aircraft of any size, due to their compact design and easy installation. With full optical testing for brightness and chromaticity, the Ultra also underwent the rigorous DO-160 testing regime and was recognized as exceeding all requirements. The Ultra has also become the leading wing light solution for numerous military and law enforcement/surveillance UAVs around the world and is very popular with aircraft manufacturers.

Packed with 28 ultra-high brightness LEDs that are the industry state-of-the-art in performance and output lumens, the **Ultras** still feature the same tiny footprint the popular Aveo **e-series** wing lights have become so well-known for in the aviation world.

Main features:

- 3-in-1 Nav/Position/Strobe
- Extremely lightweight at **103** grams
- 9-36 V DC input range
- No external power supply or strobe unit
- Light synchronization feature
- Unmatched circuit technology
- Advanced computer and goniophotometer engineered optics

Part numbers of major components that make up the equipment complying with the standards specified in ETSO are as follows:

- Ultra Galactica (RED) PN: AVE-WPSTR-54G Mod(4)
- Ultra Galactica (GREEN) PN: AVE-WPSTG-54G Mod(4)

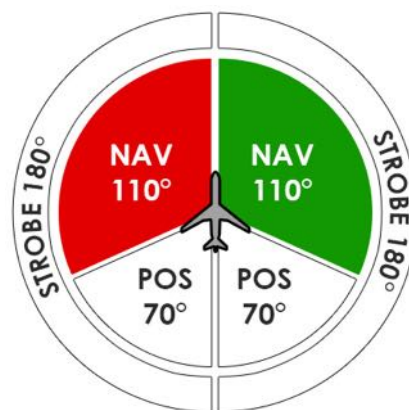

Figure 01: Features of Ultra Galactica

1.2 Operating Instructions

When installed on the aircraft, using the aircraft's power (14 or 28 volts), the **Ultra Galactica** light will be at its maximum intensity.

It meets the requirements of **ETSO-C30c** (Aircraft Position Light, **SAE A S S017 rev. B, SAE A S 8037 rev. A**) and **ETSO-C96a** (Anticollision Light System). The light operates within the range of voltage from 9 V to 36 V DC.

1.3 Installation Schematic / Wiring Diagram

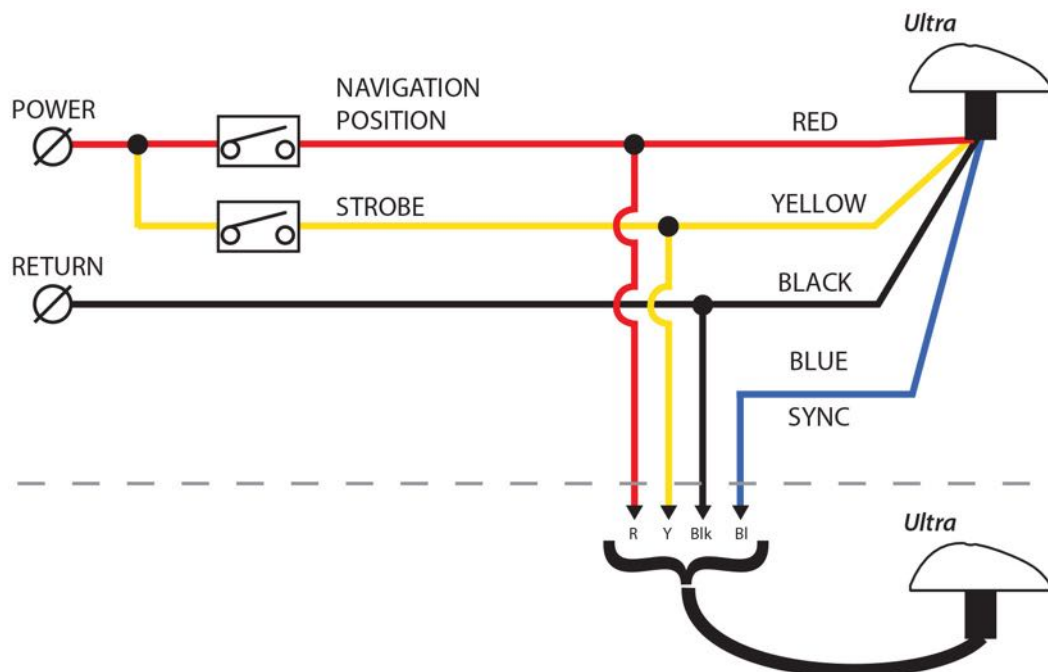

WIRES:

Teflon insulation, 500V, AWG 20, 22

Wire length from base of unit 254mm [10.00 inch] min.

1.4 Control & Power Inputs

- VCCP** - AWG 20, Positive power supply line for position (RED)
- VCCS** - AWG 20, Positive power supply line for strobe (YELLOW)
- GND** - AWG 20, Common negative power supply line (BLACK)
- SYNC** - AWG 22, Synchronization line (BLUE)

1.5 Technical Specification

Dimensions:	100 mm x 46.2 mm x 34.1 mm 3.94" x 1.819" x 1.34"
Weight:	103 g / 3.633 oz
Operating voltage range:	9 to 36 V DC
Operating temperature:	-55 °C ~ + 85 °C -67 °F ~ +185 °F

Input Power:

- Position branch (red), input power:

▪ 14 V / 0.35 A:	4.9 W
▪ 28 V / 0.18 A:	5.0 W

- Strobe branch (left), input power:

▪ 14 V / 2.8 A:	39.2 W
▪ 28 V / 1.3 A:	36.4 W

- Position branch (green), input power:

▪ 14 V / 0.32 A:	4.48 W
▪ 28 V / 0.17 A:	4.76 W

- Strobe branch (right), input power:

▪ 14 V / 2.8 A:	39.2 W
▪ 28 V / 1.3 A:	36.4 W

Repetition Flash Rate of Strobe: 50 cycles per minute

Recommended size of mounting screws:

Metric:

M5x45 DIN 7984, Stainless Steel

Flat Nylon Washer M5 – AVS-P040111909-A00 (included in the package)

Tightening torque: 1.2 Nm

UNF:

#10-32 x 1-3/4" Socket Head Cup Screw, Stainless Steel

Flat Nylon Washer M5 – AVS-P040111909-A00 (included in the package)

Tightening torque: 0.885 ft-lbs

Meets and exceeds requirements of:

- ETSO C30c, ETSO C96a
- SAE AS8017 rev. B and SAE AS8037 rev. A
- DO-160G

DO160G Test qualified:

Environment	Section	Category
Temperature / Altitude	4	F2
Temperature Variation	5	A
Humidity	6	C
Operational Shock and Crash Safety	7	B*
Vibration	8	R, Curve G, E&E1 and J S, Curve L U, Curve G
Explosive Atmosphere	9	H
Waterproofness	10	S
Fluids Susceptibility	11	F**
Sand and dust	12	D
Fungus	13	F
Salt Spray	14	T
Magnetics Effects	15	Z
Power Input	16	BRX
Voltage Spike	17	A
Audio Freq. Conducted Susceptibility	18	H
Induced Signal Susceptibility	19	AC
Radiated and Conducted Susceptibility	20	TT
Radiated and Conducted Emissions	21	B
Lightning Induced Transient Susceptibility	22	A2E2X
Icing	24	A
Electrostatic Discharge	25	A

* Aircraft Type: 5. Helicopters and All Fixed-wing, Test Type R, 20.0g all direction

**Actual fluids: Jet A-1 aviation fuel, Mobil Jet Oil II, Ethylene glycol de-icing fluid

1.6 Technical Drawing

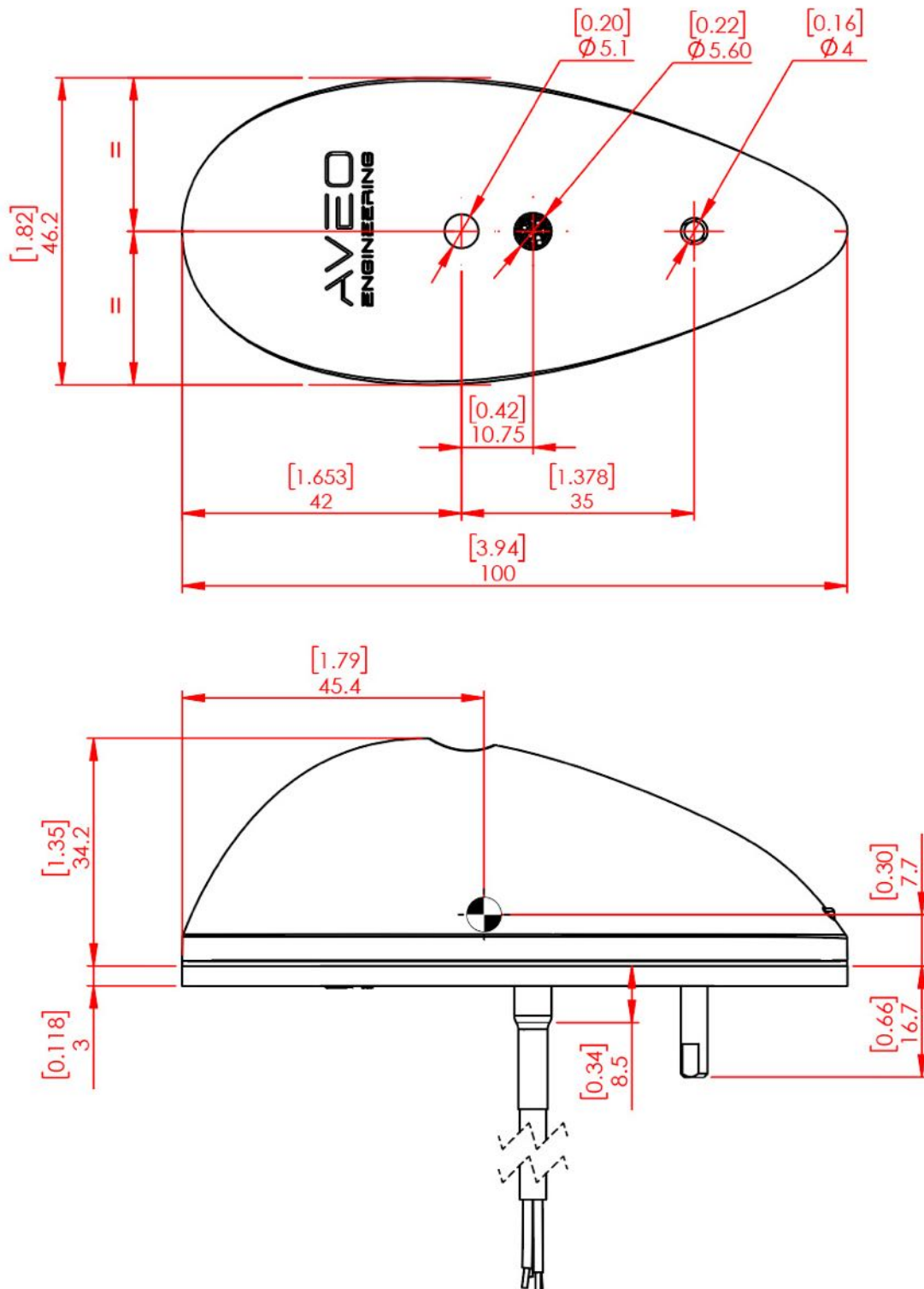

*Dimensions in mm / [inches]

1.7 Wiring Chart

Use diagram below defining the wiring size depending on the current and the wire length. Make sure you add up the current for all connected lights. If current is not given, then divide the power by the voltage.

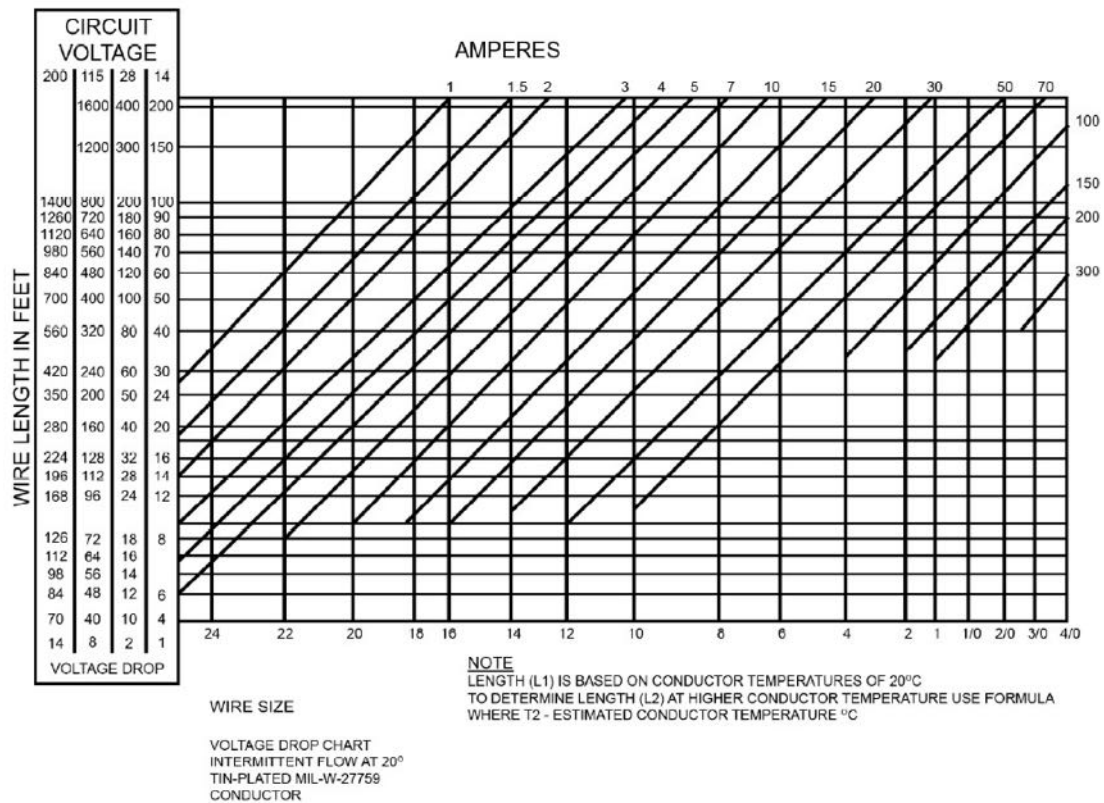

1.8 Optic Performance

Ultra Galactica Red

PN: AVE-WPSTR-54G Mod(4)

Red Position Mode

Output lumens: 166 lm
Peak intensity: 75.9 cd

Input Voltage: 28 V
Input Current (start): 0.19 A
Input Current (finish): 0.17 A

Aircraft Horizontal Plane, "0" direction is HOV0 FWD. Full range, cd

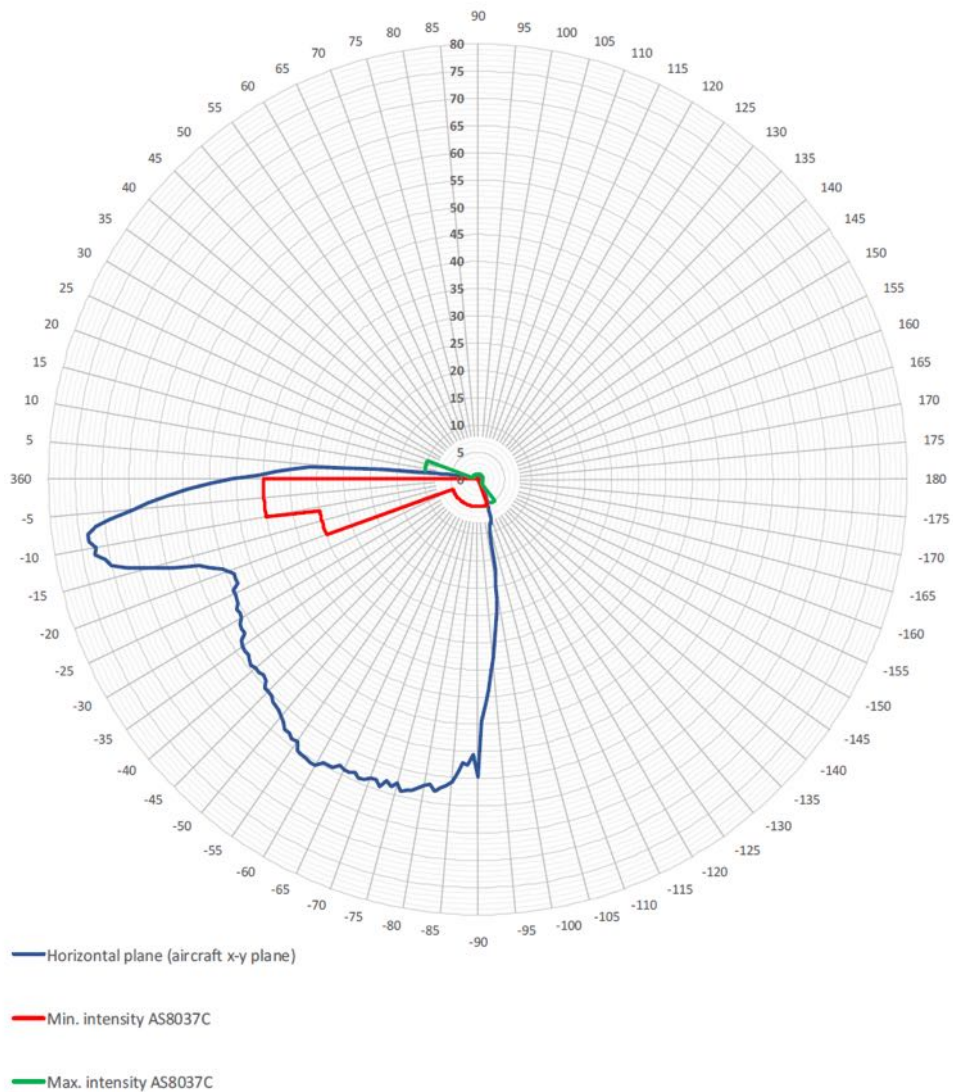

Aircraft Horizontal Plane, "0" direction is H0V0 FWD. Partial range 0-45 cd

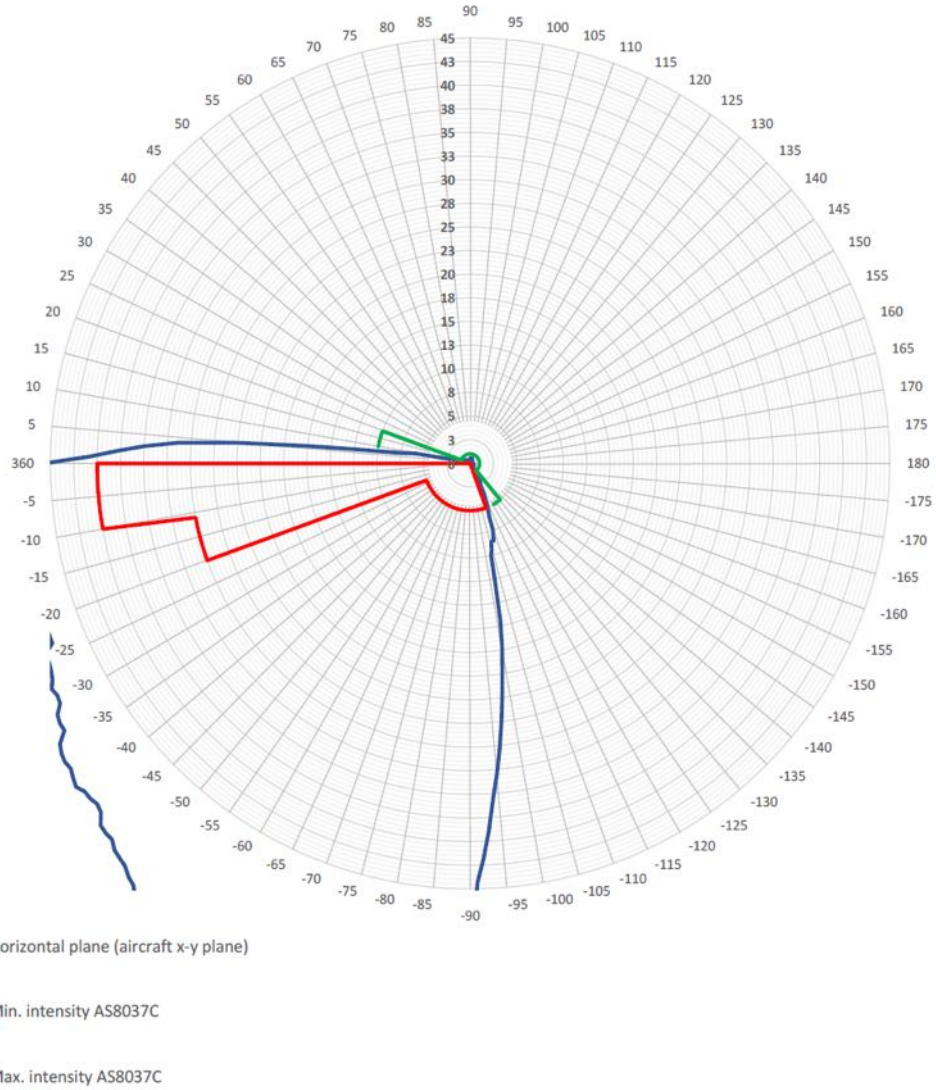

Aircraft Horizontal Plane, "0" direction is H0V0 FWD. Partial range 0-16 cd

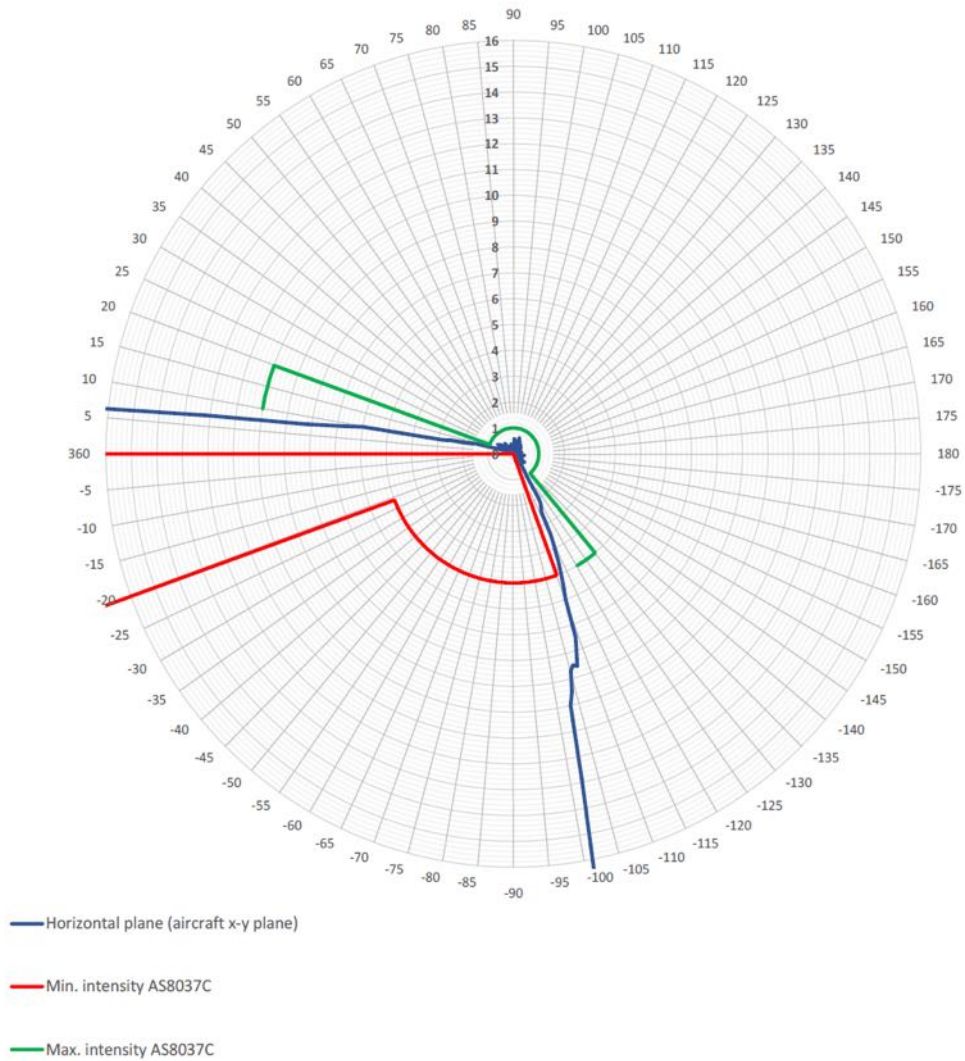

Vertical Plane 0°-180° (middle plane of aircraft), "0" direction is H0V0 FWD. Full range, cd

Grey lines show values of inclination in azimuth angles -5° and -10°

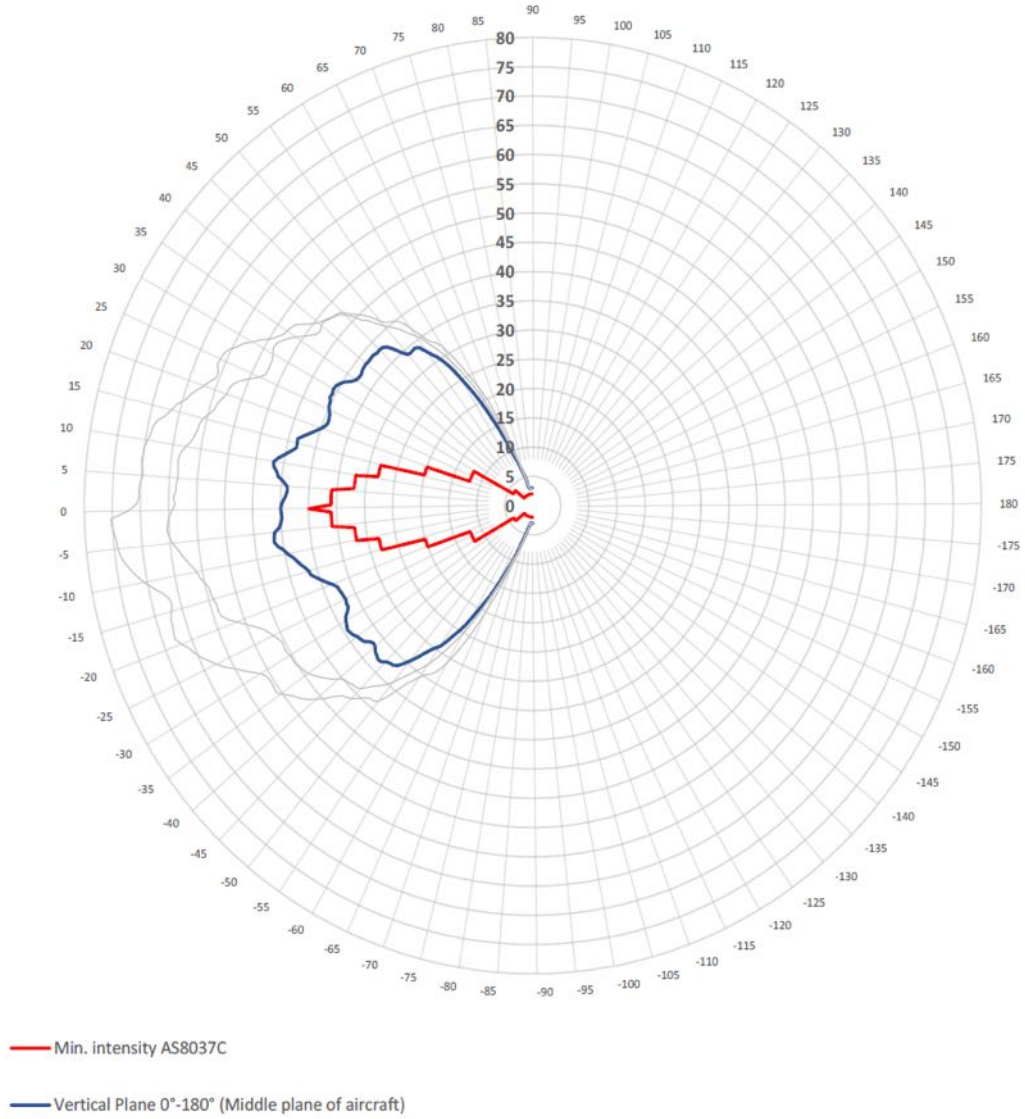

Vertical Plane -15°. Full range, cd

Grey line shows values of inclination in azimuth angle -20°

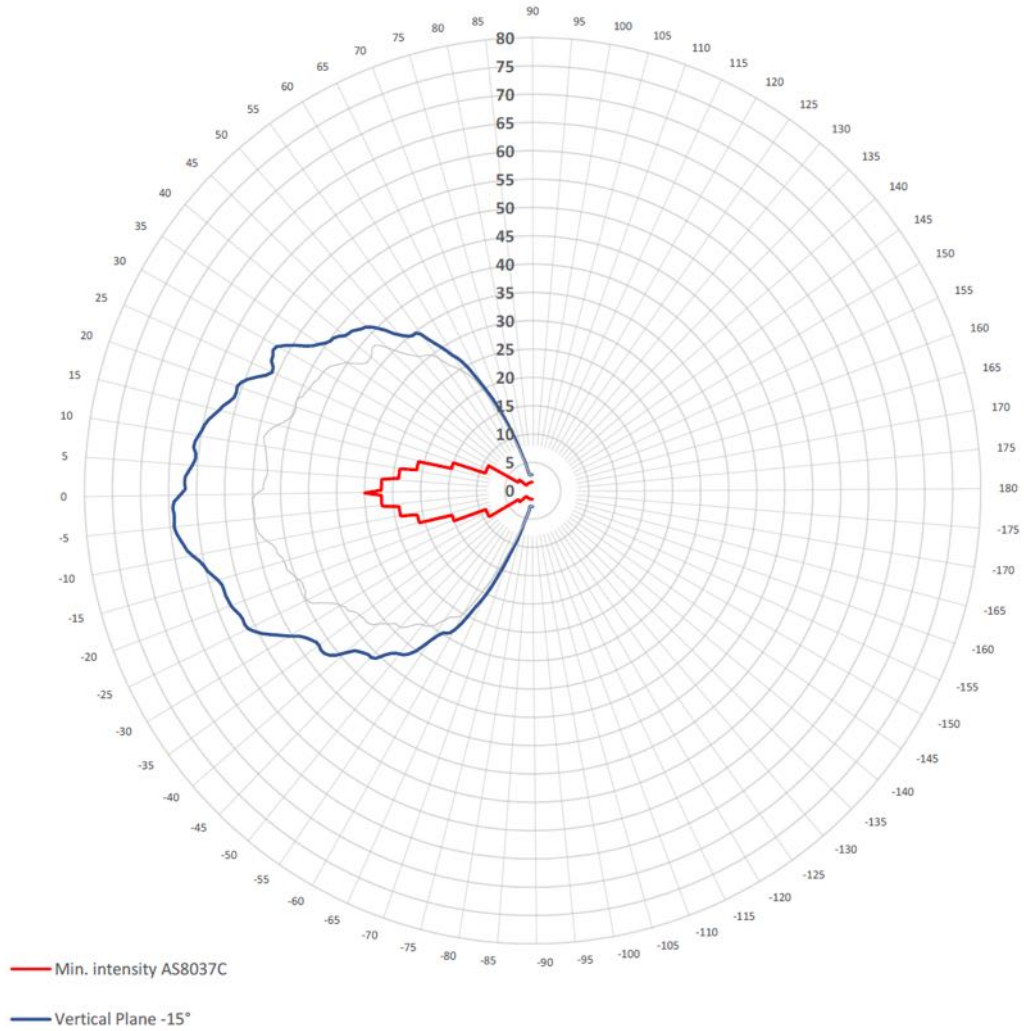

Vertical Plane -25°. Full range, cd

Grey lines show values of inclination in azimuth angles -30°-110°

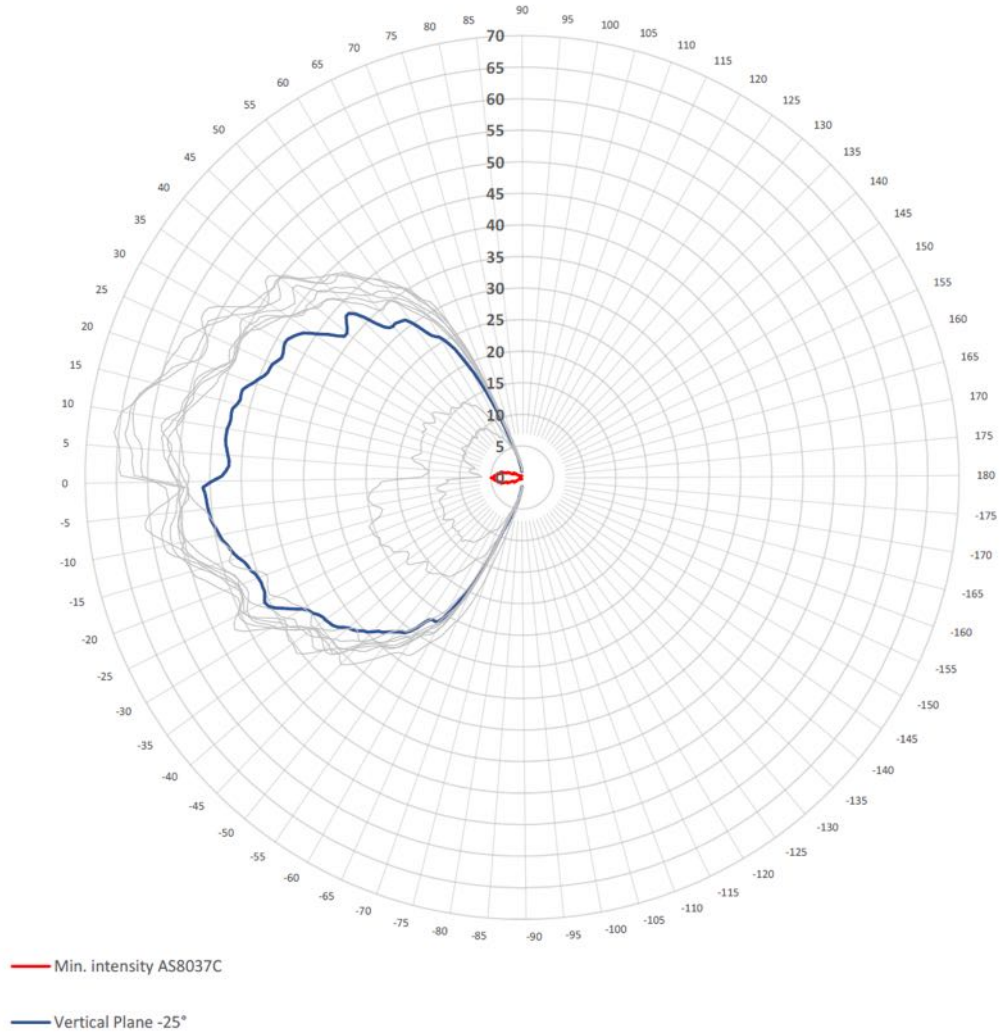

Vertical Plane -25°. Partial range, 20 cd

Grey lines show values of inclination in azimuth angles -30°-110°

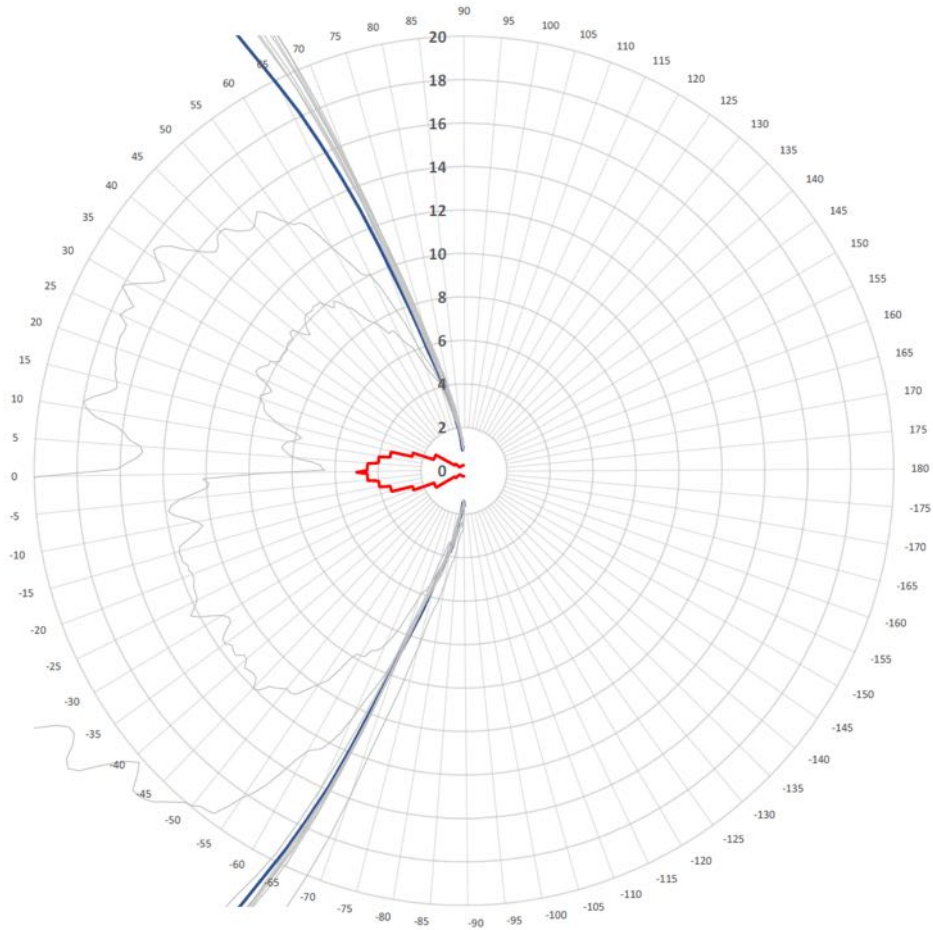

— Min. intensity AS8037C

— Vertical Plane -25°

White Position Mode

Output lumens:	134 lm
Peak intensity:	103 cd
Input Voltage:	28 V
Input Current (start):	0.19 A
Input Current (finish):	0.17 A

Aircraft Horizontal Plane, "0" direction is HOVO FWD. Full range, cd

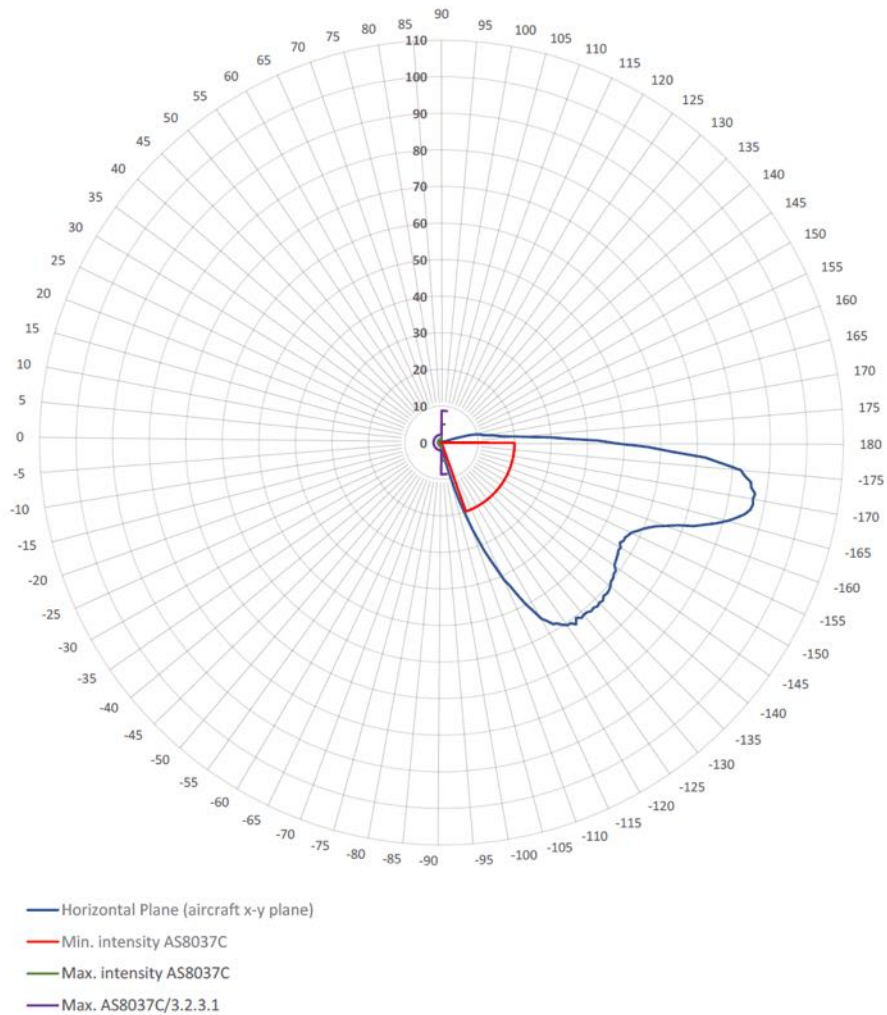

Aircraft Horizontal Plane, "0" direction is H0V0 FWD. Partial range 0-12 cd

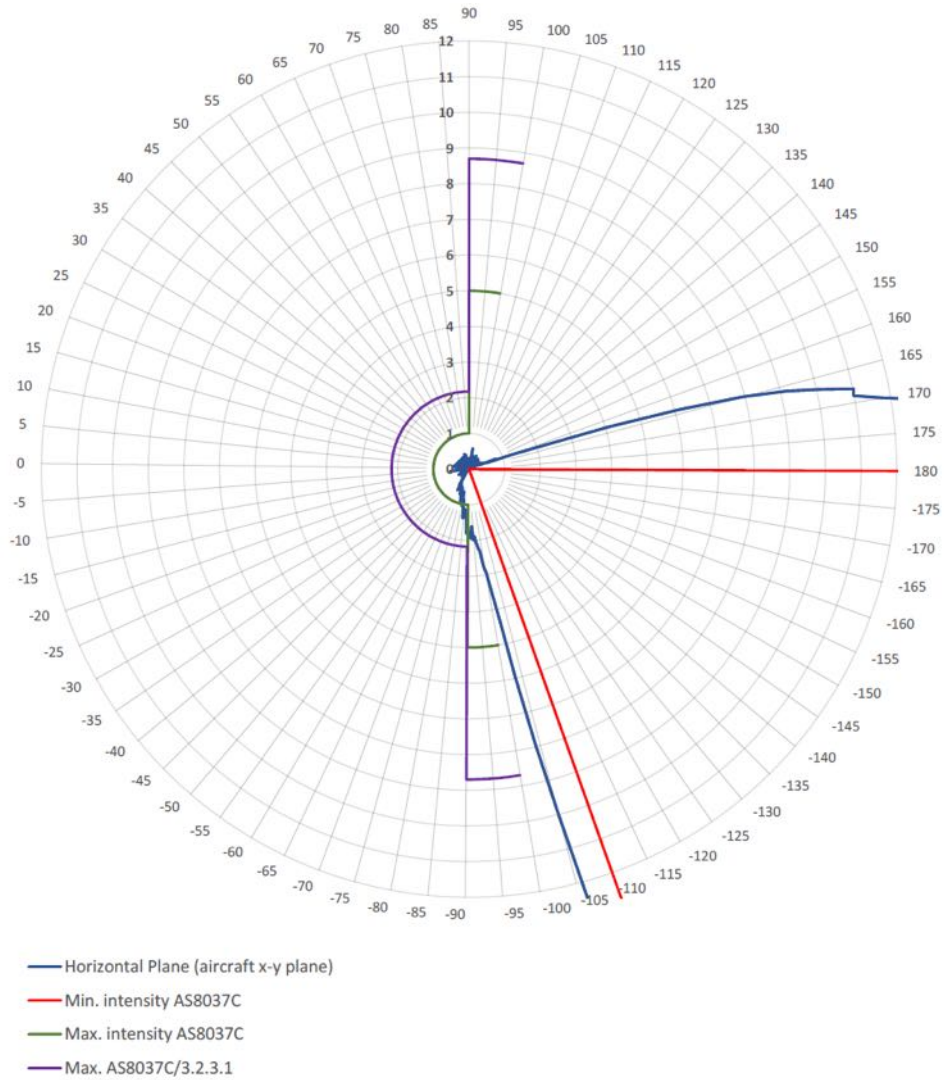

Vertical Plane (Horizontal 180°) and Vertical Plane (Horizontal -110°)

"0" direction is H0V0 FWD. Full range, cd

Grey lines show values of inclination in azimuth angles -115° ... -175°

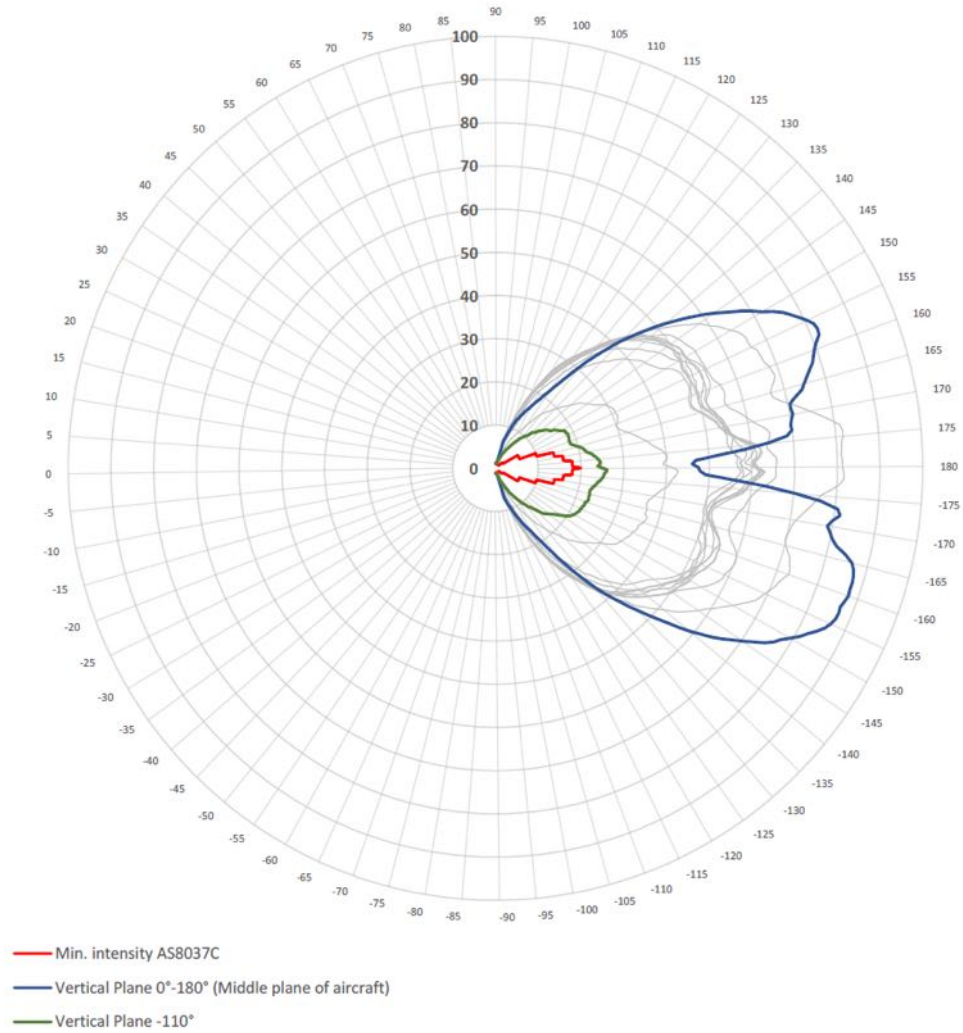

Vertical Plane (Horizontal 180°) and Vertical Plane (Horizontal -110°)

"0" direction is H0V0 FWD. Partial range, 25 cd

Grey lines show values of inclination in azimuth angles -115° ... -175°

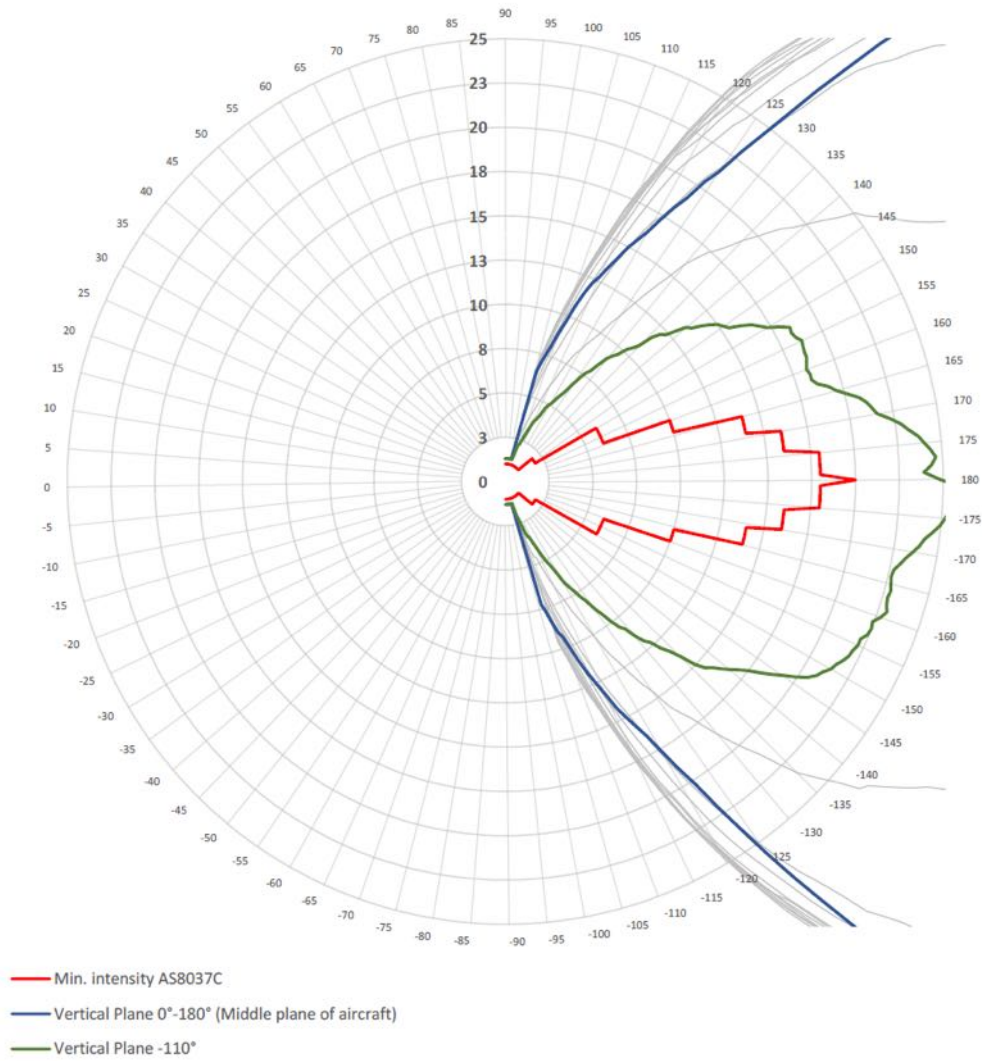

Strobe Mode

Output lumens:	1938 lm
Peak intensity:	696 cd
Input Voltage:	28 V
Input Current (start):	1.205 A
Input Current (finish):	0.98 A

Aircraft Horizontal Plane, "0" direction is HOVO FWD. Full range, Ecd

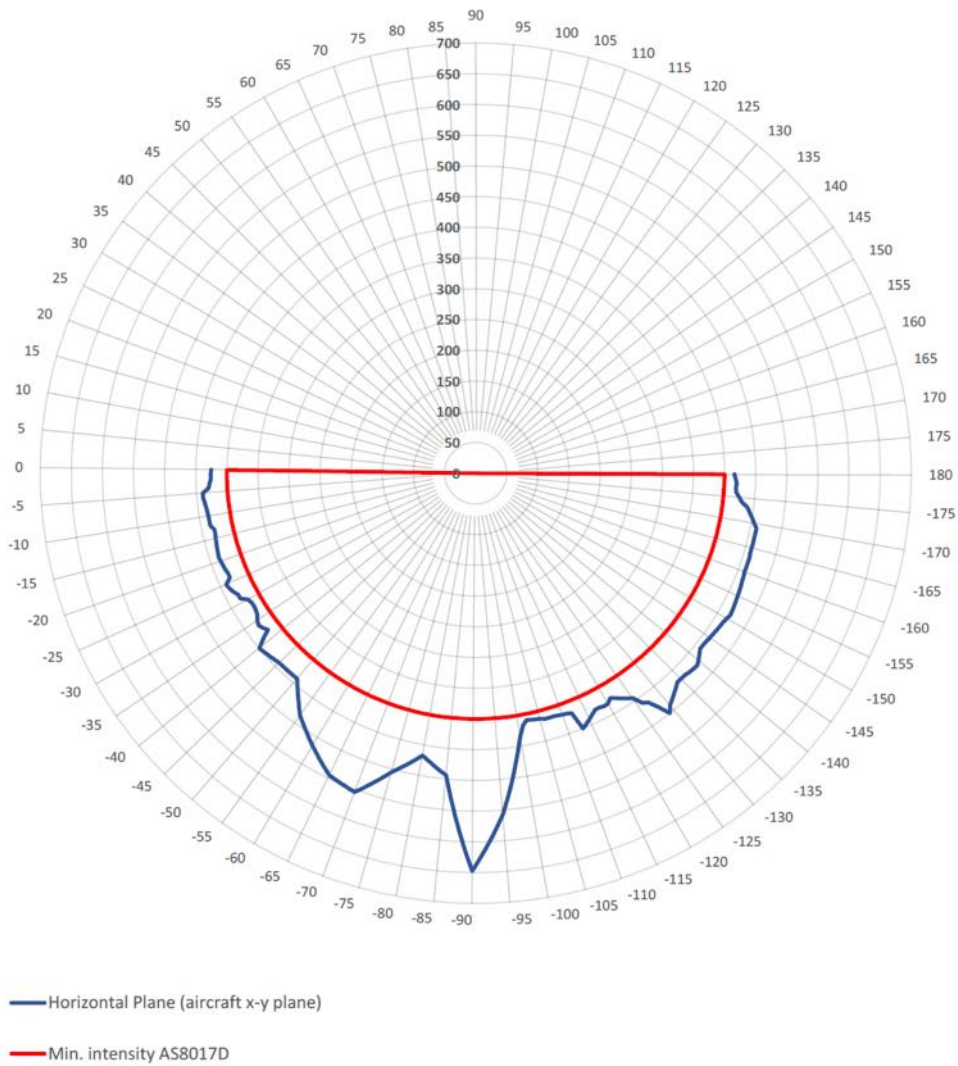

Vertical Planes (Horizontal 0°-180° and Horizontal -90°). Full range, Ecd

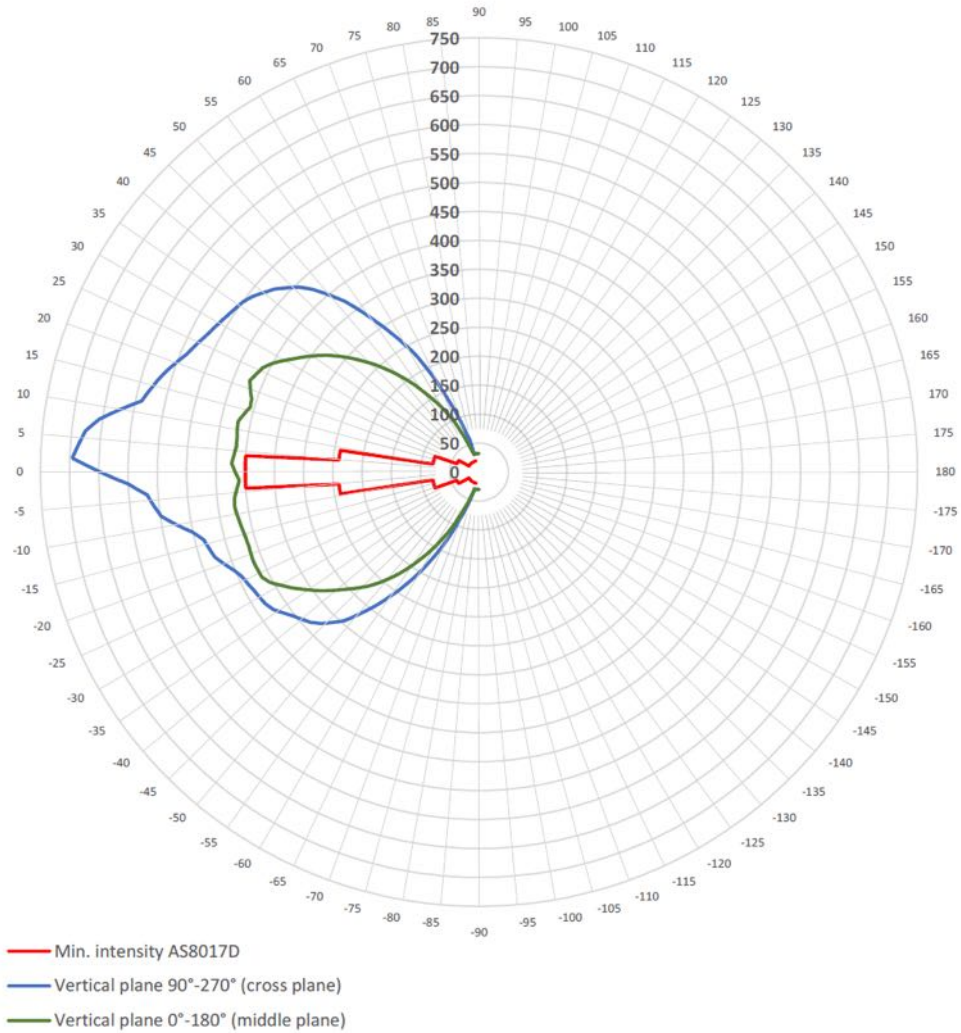

Vertical Planes (Horizontal 0°-180° and Horizontal -90°). Full range, Ecd

Grey lines show values of inclination in each of azimuth angle.

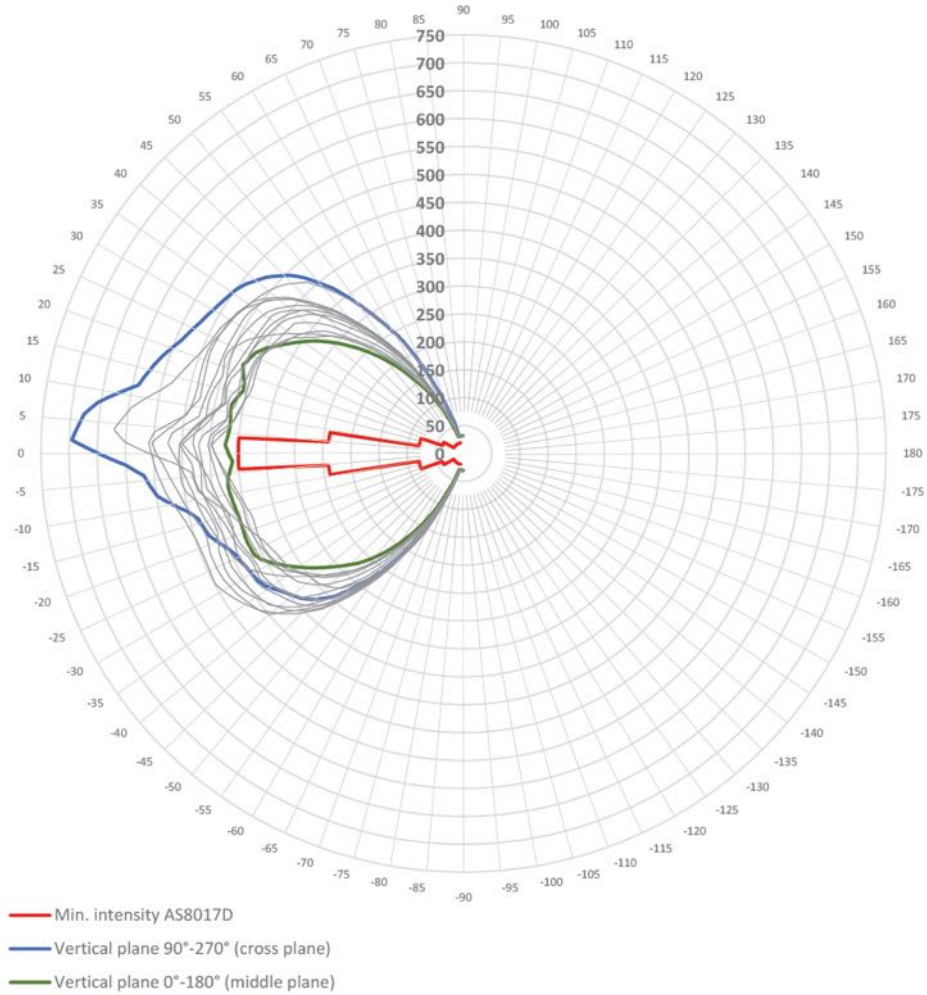

Ultra Galactica Green

PN: AVE-WPSTG-54G Mod(4)

Green Position Mode

Output lumens: 381 lm
Peak intensity: 164 cd

Input Voltage: 28 V
Input Current (start): 0.19 A
Input Current (finish): 0.17 A

Aircraft Horizontal Plane, "0" direction is H0V0 FWD. Full range, cd

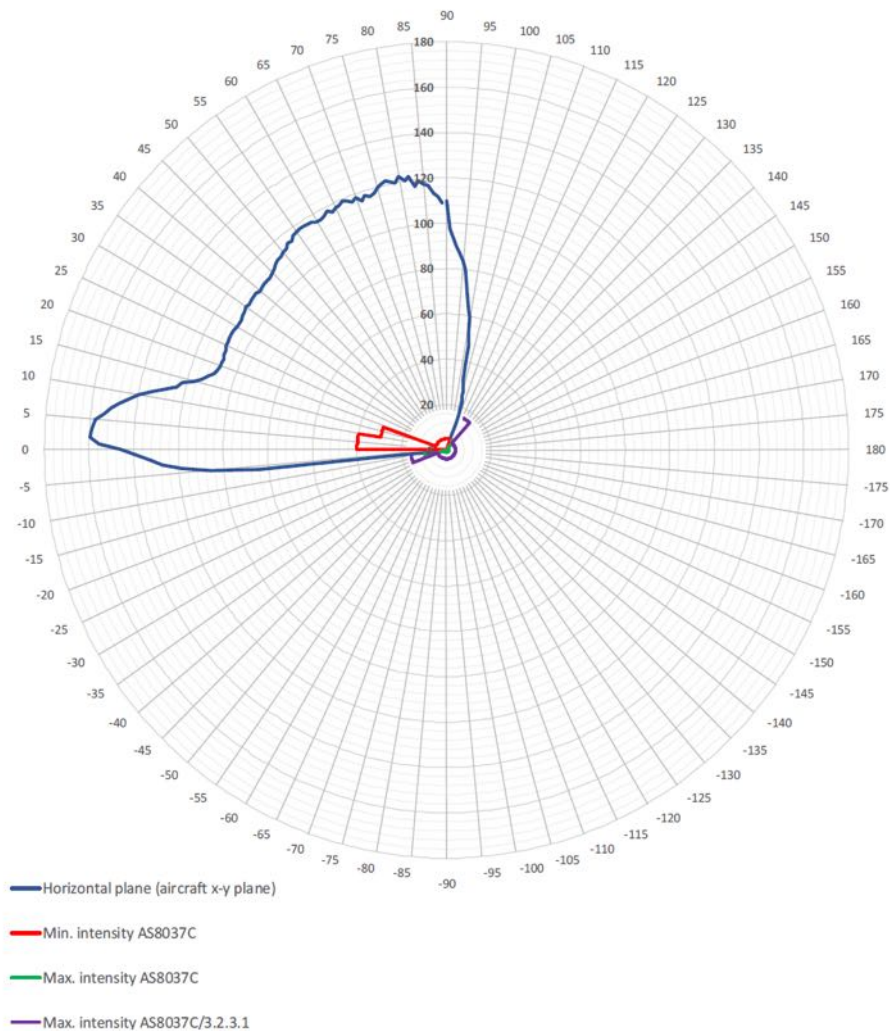

Aircraft Horizontal Plane, "0" direction is H0V0 FWD. Partial range 0-45 cd

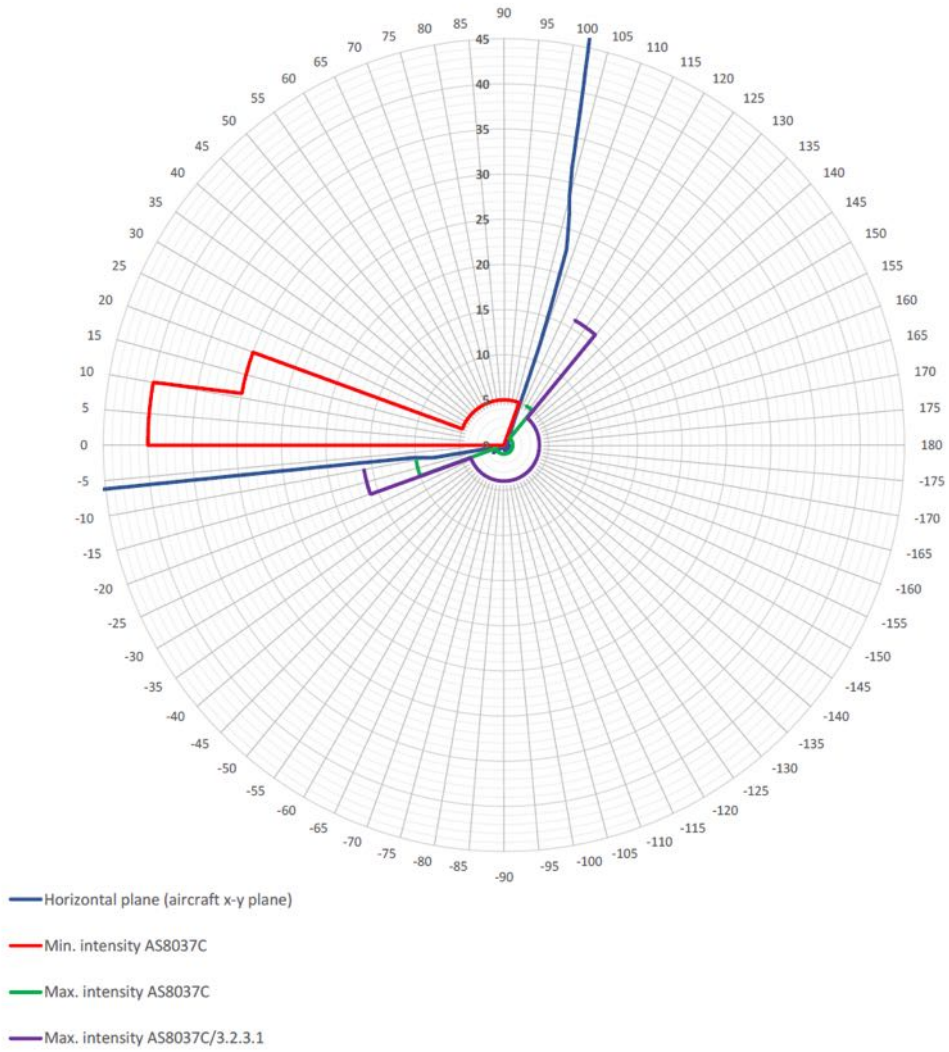

Aircraft Horizontal Plane, "0" direction is HOV0 FWD. Partial range 0-16 cd

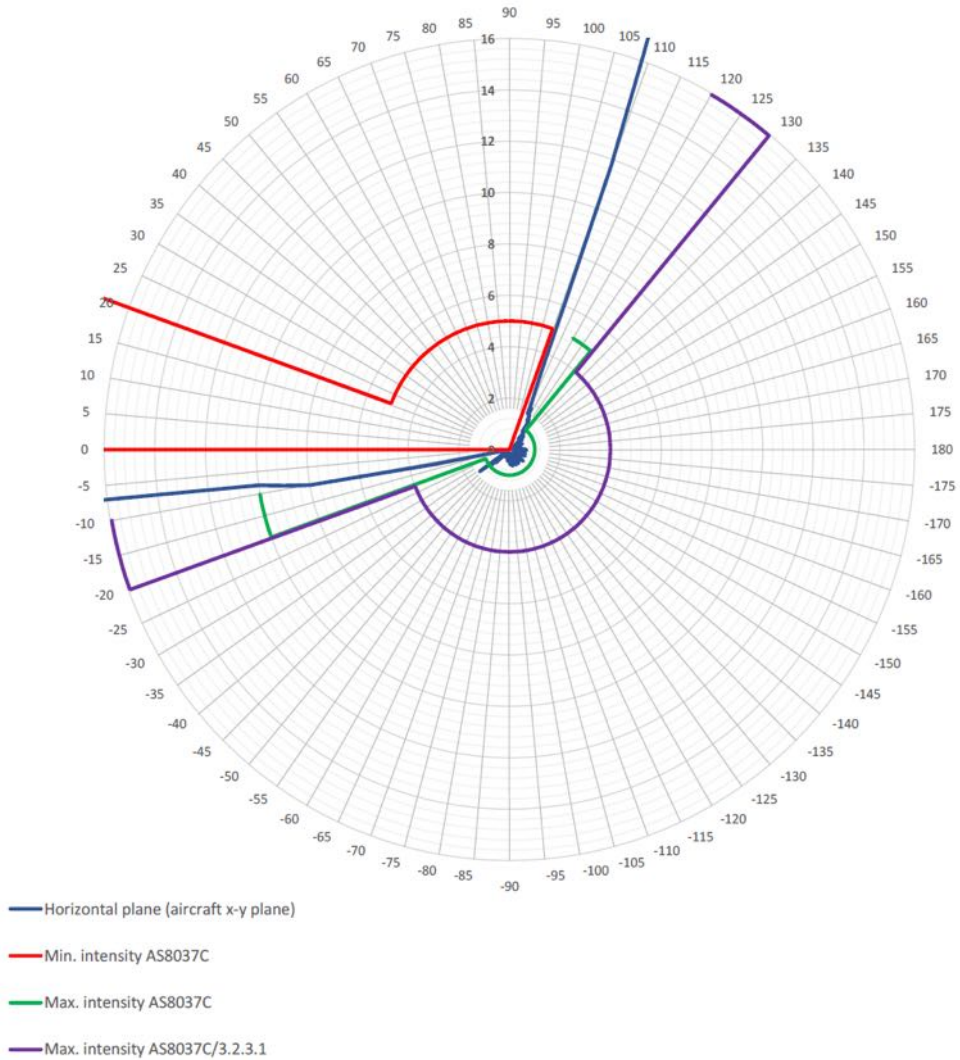

Vertical Plane 0°-180° (middle plane of aircraft), "0" direction is H0V0 FWD. Full range, cd

Grey lines show values of inclination in azimuth angles 5° and 10°

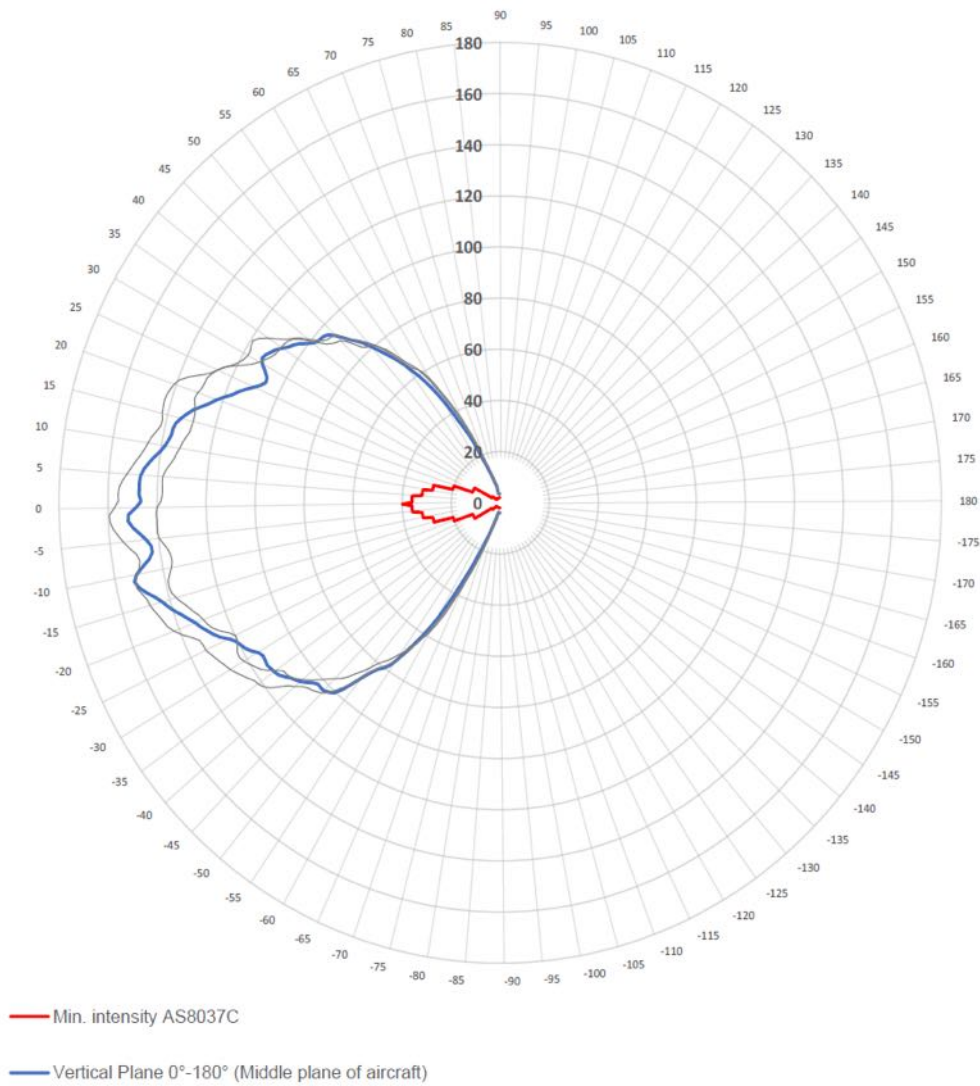

Vertical Plane 15°. Full range, cd

Grey line shows values of inclination in azimuth angle 20°

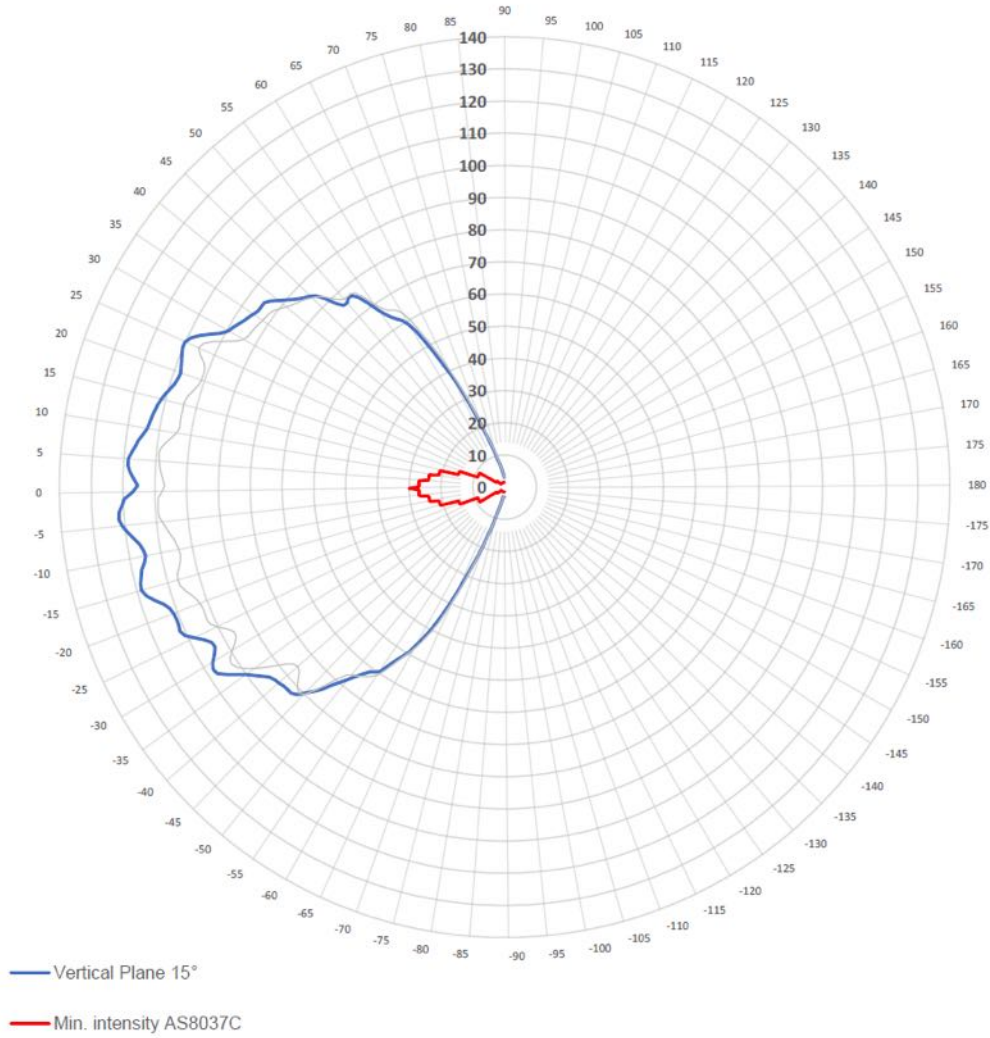

Vertical Plane 25°. Full range, cd

Grey lines show values of inclination in azimuth angles 30°-110°

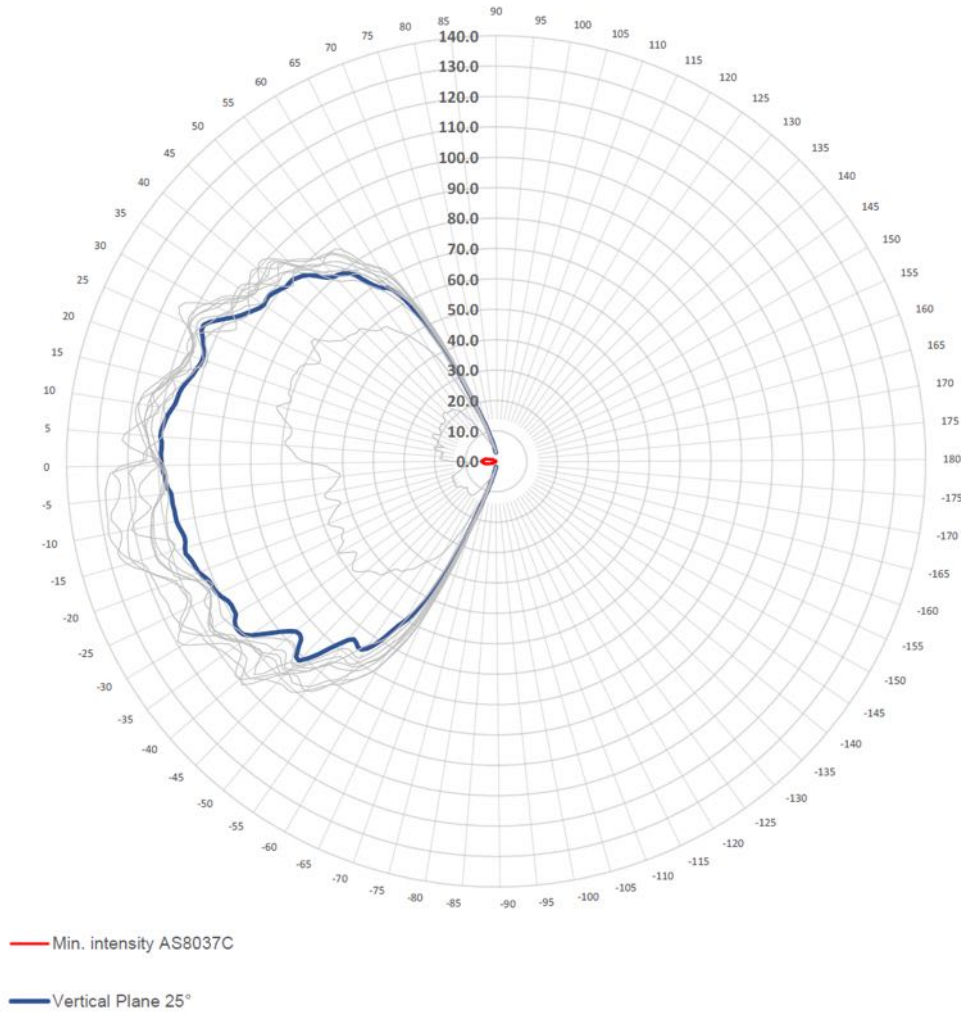

Vertical Plane 25°. Partial range, 20 cd

Grey lines show values of inclination in azimuth angles 30°-110°

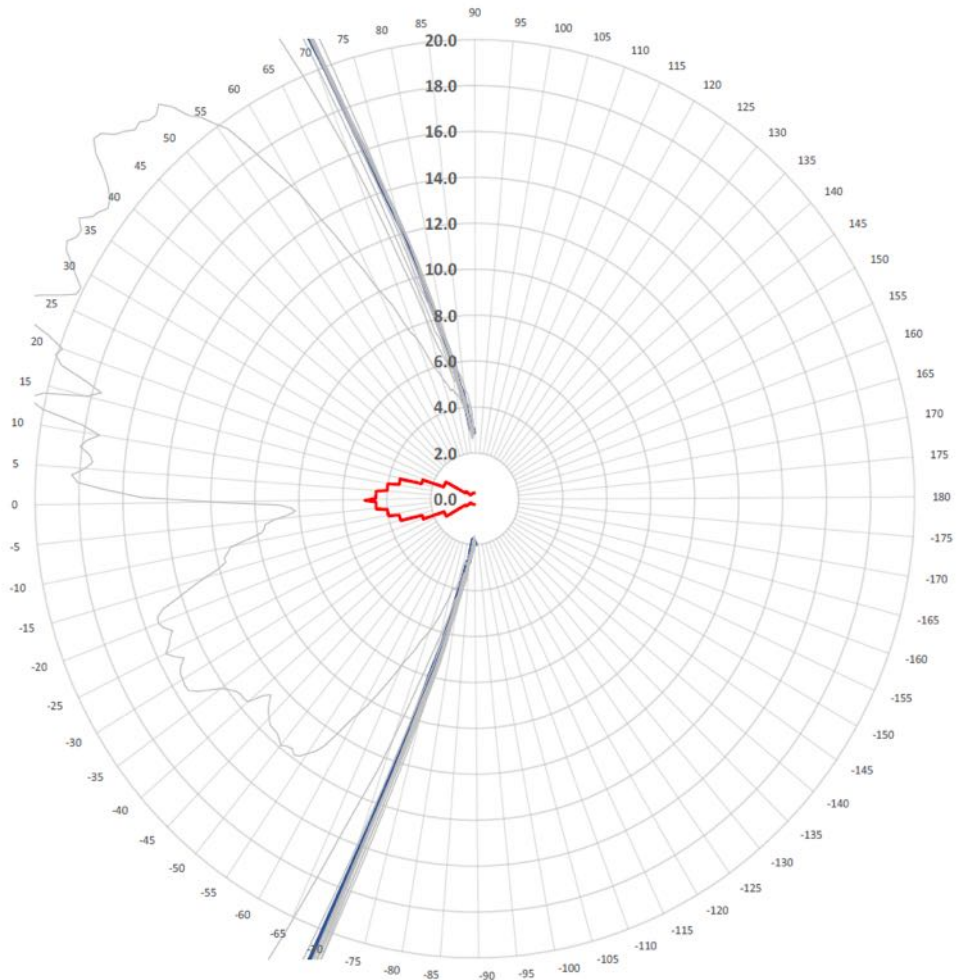

— Min. intensity AS8037C

— Vertical Plane 25°

White Position Mode

Output lumens:	122 lm
Peak intensity:	101 cd
Input Voltage:	28 V
Input Current (start):	0.19 A
Input Current (finish):	0.17 A

Aircraft Horizontal Plane, "0" direction is H0V0 FWD. Full range, cd

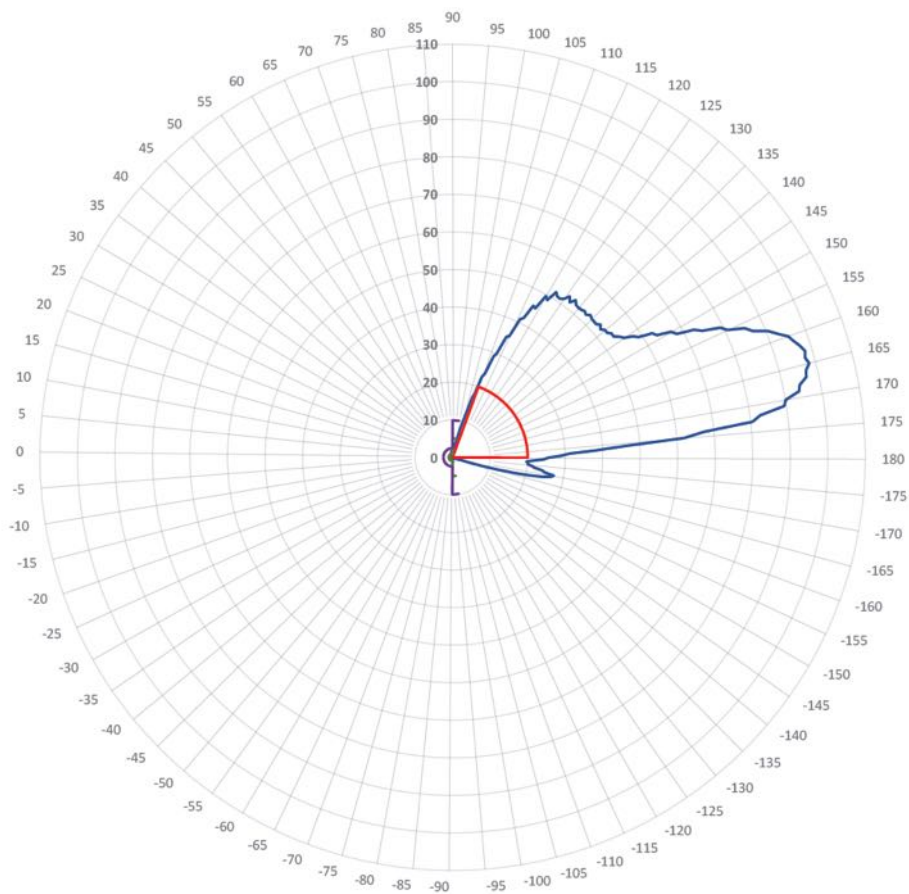

- Horizontal Plane (aircraft x-y plane)
- Min. intensity AS8037C
- Max. intensity AS8037C
- Max. AS8037C/3.2.3.1

Aircraft Horizontal Plane, "0" direction is H0V0 FWD. Partial range 0-12 cd

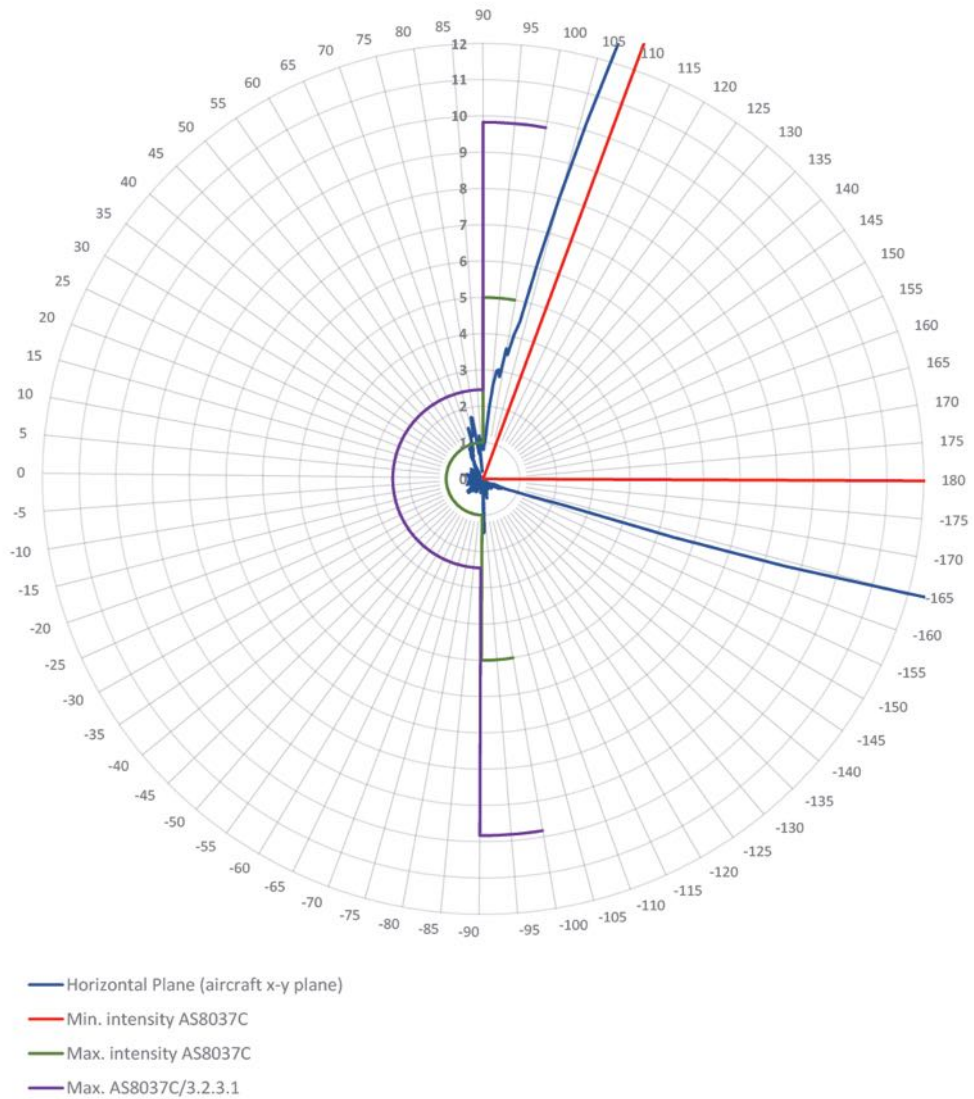

Vertical Plane (Horizontal 180°) and Vertical Plane (Horizontal 110°)

"0" direction is HOV0 FWD. Full range, cd

Grey lines show values of inclination in azimuth angles 115° ... 175°

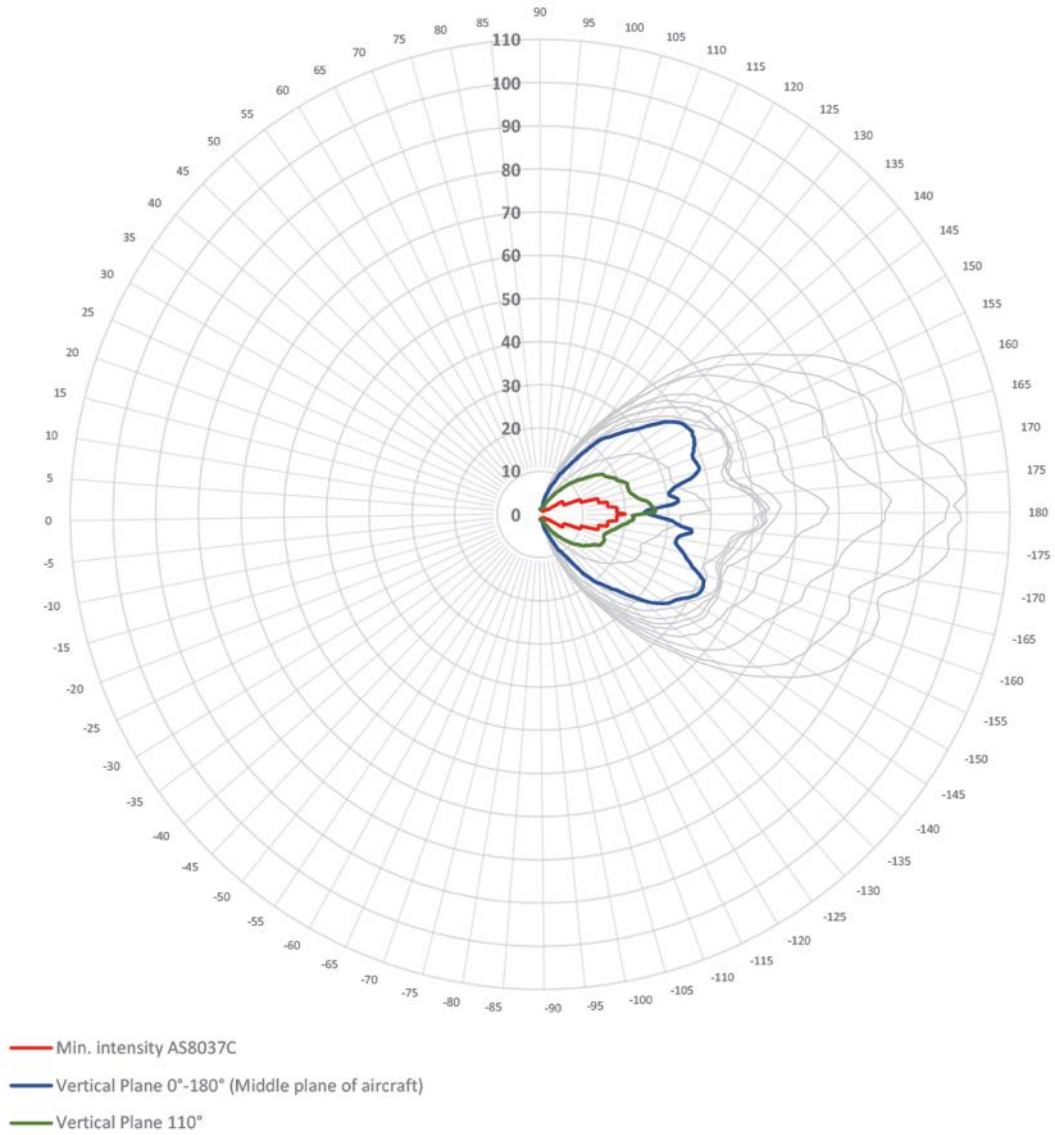

Vertical Plane (Horizontal 180°) and Vertical Plane (Horizontal 110°)

"0" direction is H0V0 FWD. Partial range, 25 cd

Grey lines show values of inclination in azimuth angles 115° ... 175°

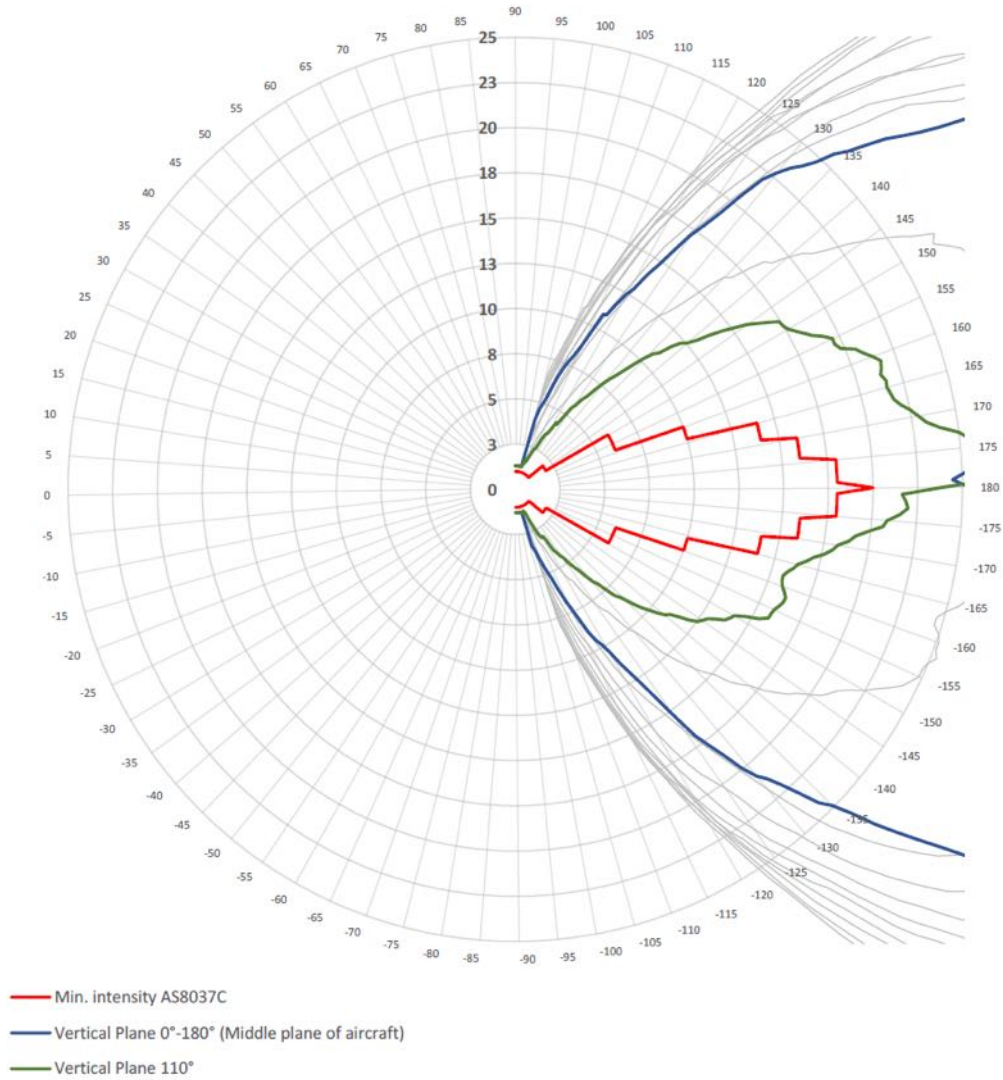

Strobe Mode

Output lumens: 2249 lm
Peak intensity: 673 cd

Input Voltage: 28 V
Input Current (start): 1.201 A
Input Current (finish): 0.98 A

Aircraft Horizontal Plane, "0" direction is HOV0 FWD. Full range, Ecd

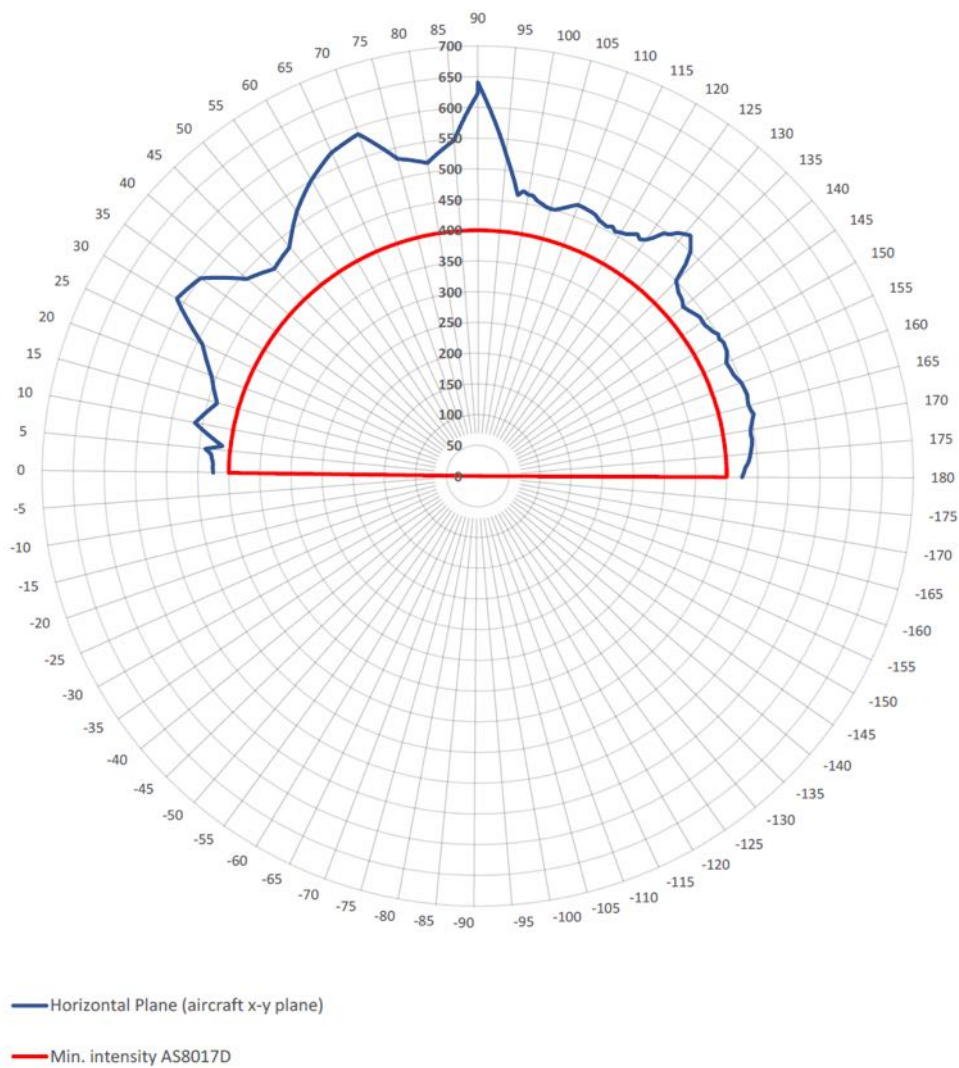

Vertical Planes (Horizontal 0°-180° and Horizontal 90° - 270°). Full range, Ecd

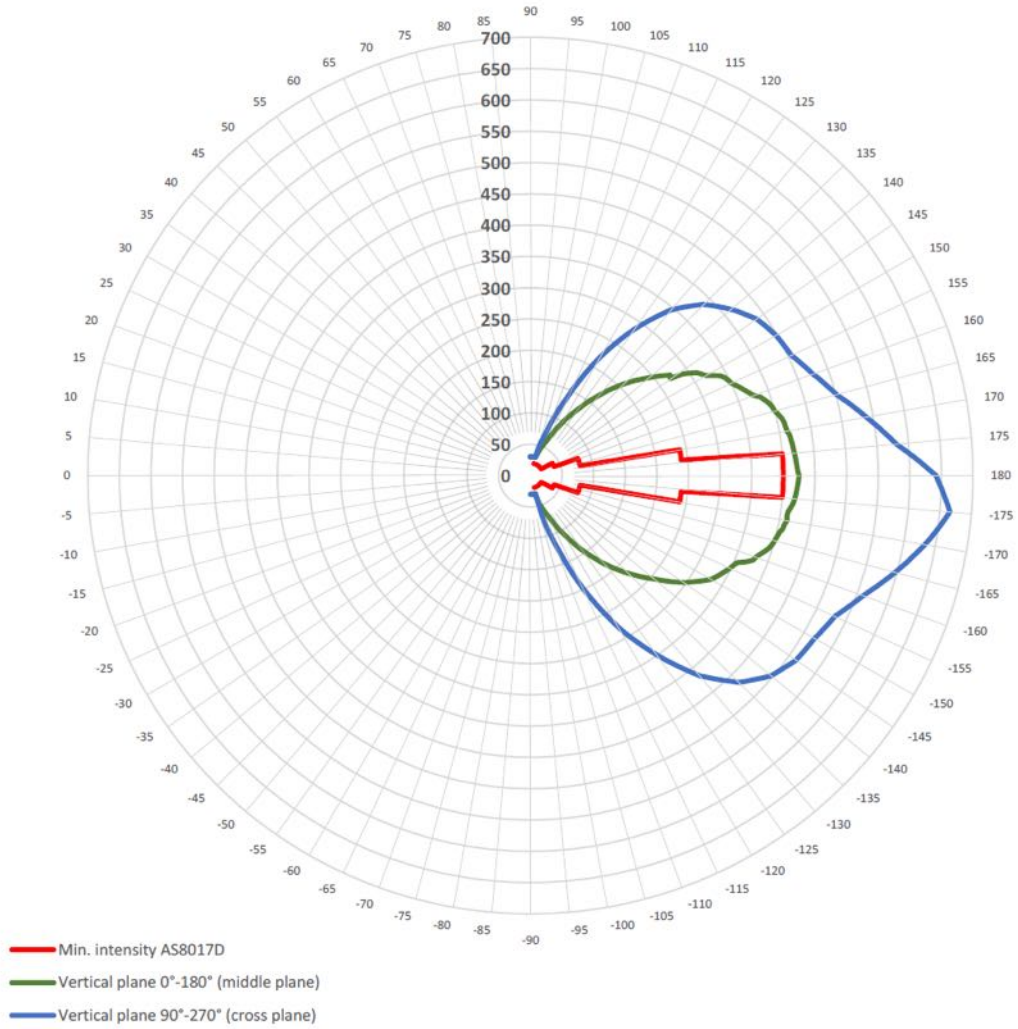

Vertical Planes (Horizontal 0°-180° and Horizontal 90° - 270°). Full range, Ecd

Grey lines show values of inclination in each of azimuth angle.

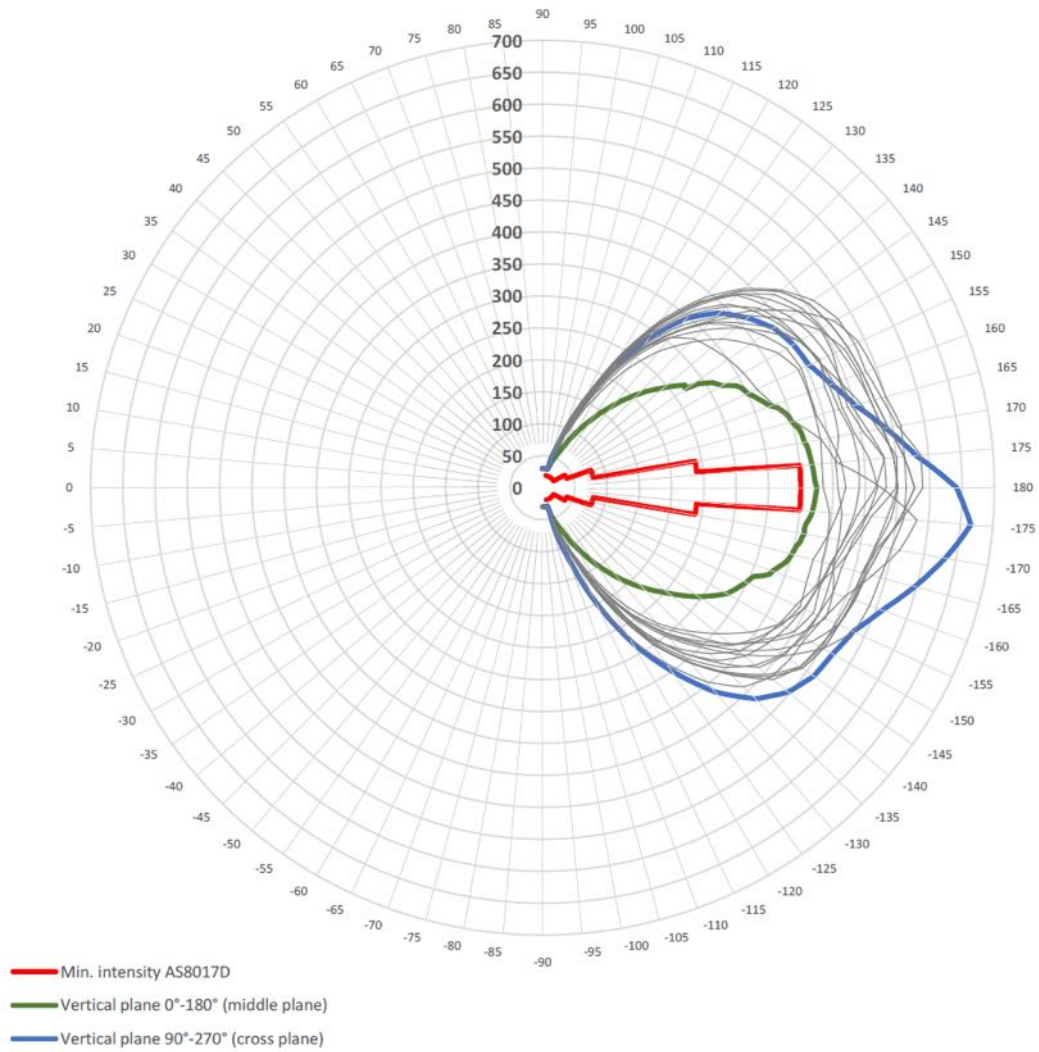

1.9 Equipment Limitation

Ultra Galactica™ should only be powered by 9-36 VDC, typically a 14V or 28V aircraft battery.

This article meets the minimum performance and quality control standards required by the technical standard orders ETSO C30c and ETSO C96a. Installation of this article requires separate approval.

Deviations

None

1.10 Testing the Lights before Installation

All Aveo Aviation lights undergo rigorous testing prior to being released from our engineering manufacturing department. This testing involves a burn-in time as well as other function testing. No light is released for sale without undergoing this extensive operational testing.

When you receive the **Ultra Galactica** light, and wish to test the function of the light prior to installation on your aircraft, please observe the following procedure:

1. Review the written information that is enclosed in the packaging. Warranty information as well as a cautionary note about power supply removal is enclosed in each package.
2. Remove the light from the package. Note that there are four (4) wires coming from each light. The wires are as follows:

Black	ground (negative lead)
Red	position/navigation light function (positive lead)
Yellow	strobe light function (positive lead)
Blue	synchro

3. Testing the function of the light can be accomplished using a regular 12V/5A DC power supply (not a battery charger).

Connect the black wire to the ground (negative) leads of a power supply, then connect the yellow or red wire to the positive (+) leads on the power supply. The light should start flashing (yellow wire = strobe light) or lighting (red wire = green/red and white light). Connecting the blue wires from each **Ultra Galactica** light together (and not to the ground or positive terminals on the battery) should result in flashing all lights at once. It indicates that the synchronization feature is working properly.

When installed on the aircraft and using the aircraft's power (14 or 28 volts), the light will be at its maximum intensity.

If the tests are successfully completed, the lights can be installed on the aircraft.

IMPORTANT NOTES:

1. Under no circumstances should any power supply other than a 9-36V DC, or a 12/24V battery be used to test the light. Do not use: Battery chargers, battery back-up power devices or other bench avionics testing methods to test the aviation light. The light is functional between 9 and 36 V. Use of a battery charger or other power unit to test the light will void the warranty and may damage the light.
2. All power supplies for existing strobe lights, flasher beacons, etc. are required to be removed from the aircraft prior to the installation of the Aveo light.



If you have any questions regarding the installation of the lights, please refer to our web site: www.aveoengineering.com and check FAQ and other links on our aviation lights web page.

1.11 Notes on Installation

Recommended size of mounting screws:

Metric:

M5x45 DIN 7984, Stainless Steel

Flat Nylon Washer M5 – AVS-P040111909-A00 (included in the package)

Tightening torque: 1.2 Nm

UNF:

#10-32 x 1-3/4" Socket Head Cup Screw, Stainless Steel

Flat Nylon Washer M5 – AVS-P040111909-A00 (included in the package)

Tightening torque: 0.885 ft-lbs

Screw length depends on placement of screws on wingtips.

1.12 Care and Cleaning of Lights

Aveo Engineering Aviation Lights are factory polished and delivered as ready to install on the aircraft.

Upon installation, apply one or two coats of quality automotive polish. This should protect the lights from dirt and other environmental factors. Once or twice a month, just refresh the polish and buff the lights by hand.

1.13 Continued Airworthiness Information

a. Circuit/Wiring Protection

Each **Galactica** series light features a **Negative Temperature Coefficient** (NTC) circuit that limits internal temperatures by attenuating operating current (with corresponding reduction of brightness) when internal temperatures reach a certain threshold. This proprietary circuitry is intended for protecting the light itself, and associated aircraft wiring, from a thermal runaway condition. The operation of strobes without airflow is recommended to be limited in order to avoid heat buildup. This NTC circuitry feature enables the life of LEDs and electronic components to be tripled and thereby provide an even great margin of safety for continued airworthiness due to the dramatic enhancement of electronics reliability.

b. Periodic Inspection Procedure

The **Galactica** lights should always be checked for proper operation during preflight. This procedural information is already provided in all general aviation aircraft flight manuals.

The lights should be visually examined for general condition, proper operation, and correct installation at each inspection to be carried out annually and/or after 100 hours of operation. Any debris or atmospheric deposits accumulated on the surface of the lights should be removed using a UV Wax such as Farecia Profile UV Wax to ensure ongoing optical clarity. In addition, refer to section 1.11 of installation manual for detailed cleaning instructions.

The following procedure shall be performed, firstly, in the steady mode and secondly, in the strobe mode:

1. Put on polarized sunglasses or welder goggles to prevent eye damage when looking into the lights.
2. Turn the lights on.
3. Examine the individual LEDs in accordance with the figures 2-4 below. *If any of the LEDs fail, the light shall be removed and sent to Aveo Engineering for replacement under the Warranty Program.*

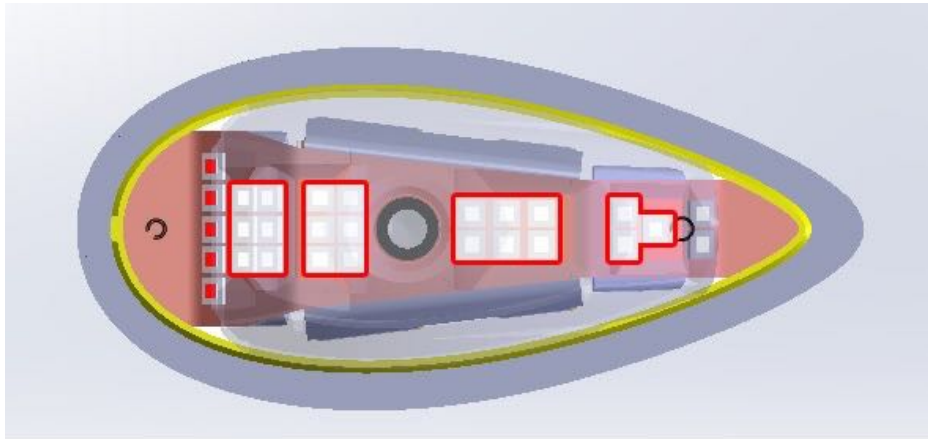

Figure 2: Strobe LEDs

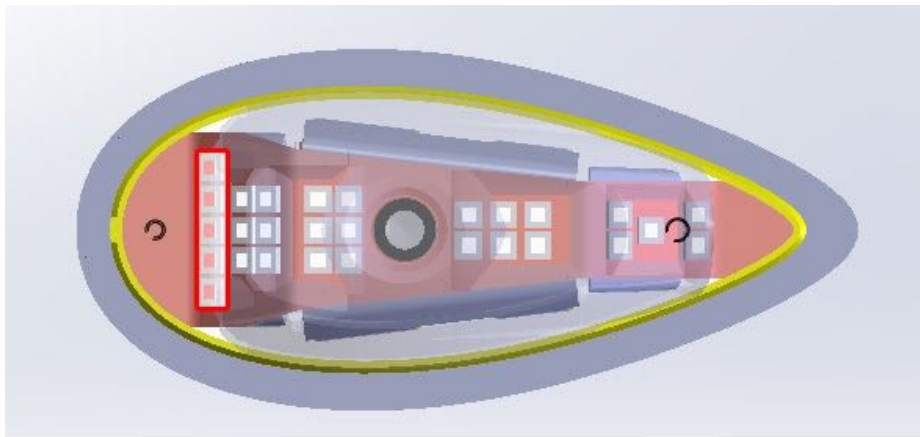

Figure 3: Position LEDs (colored)

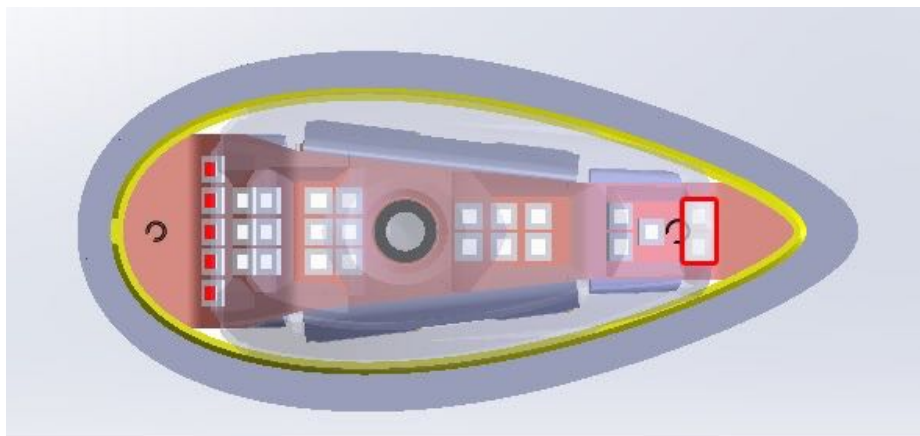

Figure 4: Position LEDs (white)

1.14 ETSO Requirement Deviation

This article deviates from ETSO C30c and ETSO C96a by the usage of newer revisions of the following standards:

- SAE AS 8017 rev. B used instead of SAE AS 8017 rev. A,
- SAE AS 8037 rev. A used instead of SAE AS 8037 initial release.

1.15 RoHS Compliance Statement

Scope

This statement clarifies Aveo Engineering's compliance with European Union Directive 2015/863/EU on the restriction of the use of certain hazardous substances in electrical and electronic equipment ("RoHS") that took effect on June 4, 2015. The RoHS Directive restricts the sale of electronic equipment containing certain hazardous substances in the European Union including:

Cadmium(Cd): 0.01%
 Mercury: 0.1%
 Lead(Pb): 0.1%
 Hexavalent chromium (Cr6+): 0.1%
 Polybrominated biphenyls (PBB): 0.1 %;
 Polybrominated diphenyl ethers (PBDE): 0.1 %
 Bis(2-Ethylhexyl) phthalate (DEHP): 0.1% (added in 2015);
 Benzyl butyl phthalate (BBP): 0.1% (added in 2015);
 Dibutyl phthalate (DBP): 0.1% (added in 2015);
 Diisobutyl phthalate (DIBP): 0.1% (added in 2015)

Compliance

Aveo Engineering certifies that all products sourced from manufacturing facilities comply with the environmental standards set forth by the Directive 2015/863/EU, recast amendment of RoHS Directive 2011/65/EU Article (4), and do not contain any of the above-mentioned, 10 hazardous substances above the specified limits. All products manufactured by Aveo Engineering are RoHS-compliant. With regards to RoHS-2 CE marking, product packaging is labeled attesting conformity if required.

References

Directive 2015/863/EU of the European Parliament and of the Council on the restriction of the use of certain hazardous substances in electrical and electronic equipment.

1.16 EU REACH Regulation (EC) No. 1907/2006

Aveo Engineering declares that no chemicals are produced and that none of the chemicals used during the production process or needed for the product maintenance or service, is listed on the current European Chemicals Agency's Candidate list of Substances of Very High Concern for Authorization.